

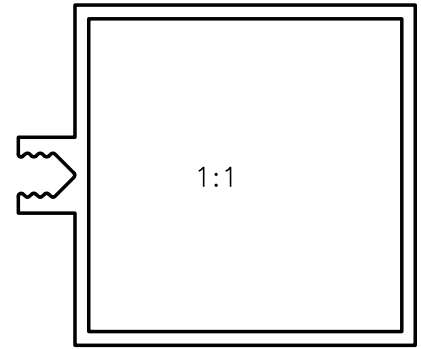

2925  
10618  
22717

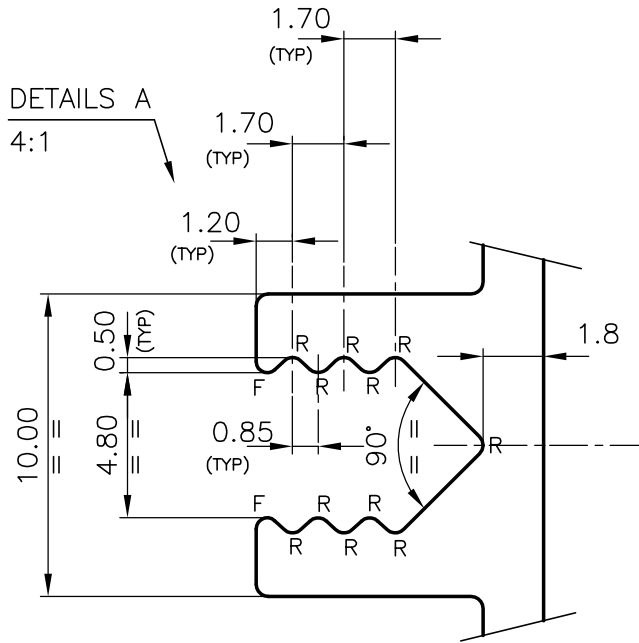

NOTE:-  
1.R=0.4 RADII(11-PLCS)  
2.F=FULL RADII(2-PLCS)

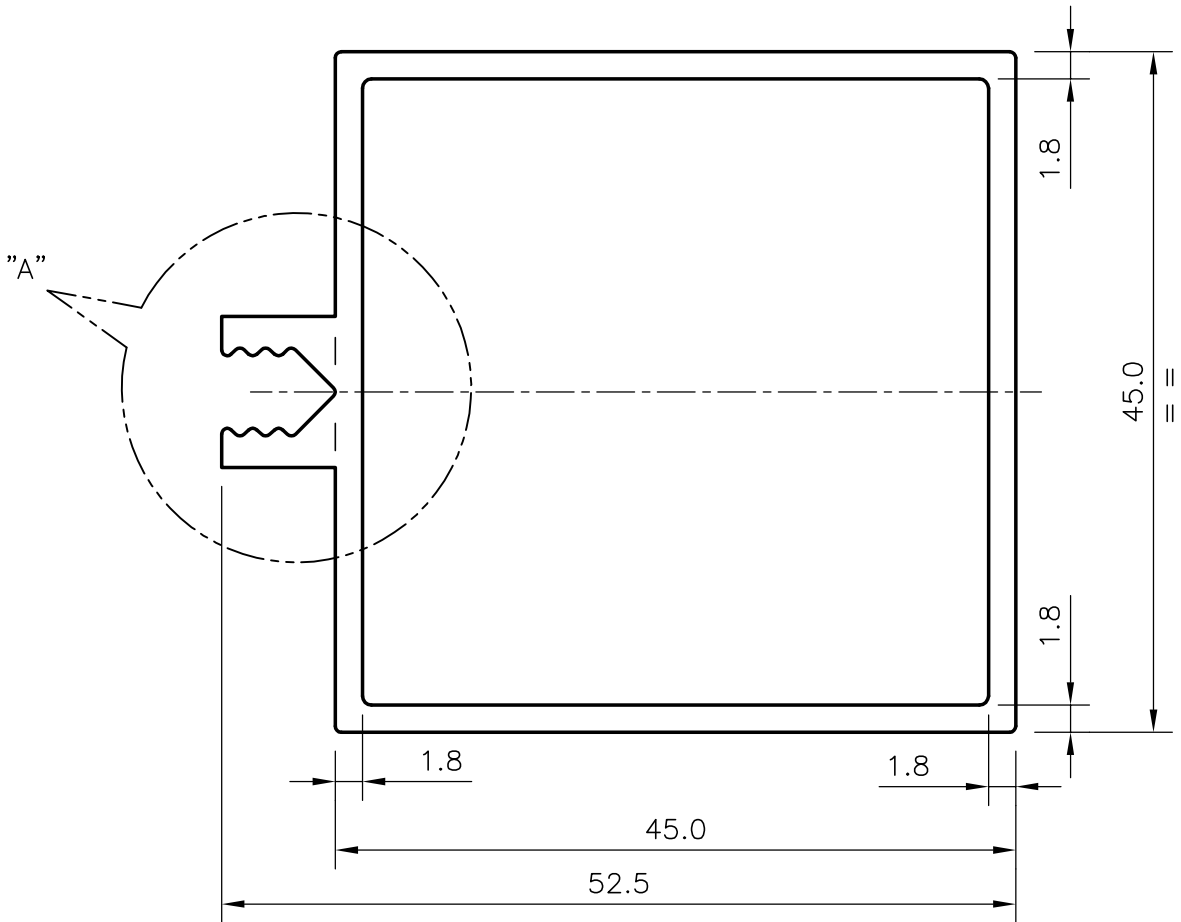

 SYMBOL OF QUALITY AN ISO 9002 COMPANY	<b>JINDAL ALUMINIUM LTD.</b> BANGALORE-560073 (INDIA)	NAME	DATE
		DRAWN	RANGASWAMY 19-03-01
1. ALL DIMENSIONS ARE IN mm. 2. ROUND OFF ALL SHARP CORNERS WITH 0.40 mm. 3. TOLERANCES WILL BE AS PER I.S. 6477-1983 UNLESS OTHERWISE SPECIFIED		CHECKED	
		APPROVED	
PARTY'S NAME	GENERAL CATEGORY (HYDERABAD MARKET)	SCALE	2:1 & 4:1
PARTY'S DRAWING No.	AS PER SAMPLE	WEIGHT kg/m	0.951
ALLOY & TEMPER	HE9 WP	SECTION No.	22717
DESCRIPTION	WINDOW SECTION	DRAWING No.	22717