

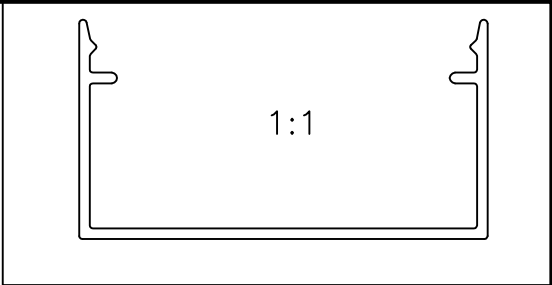

P-4554
2990
22729

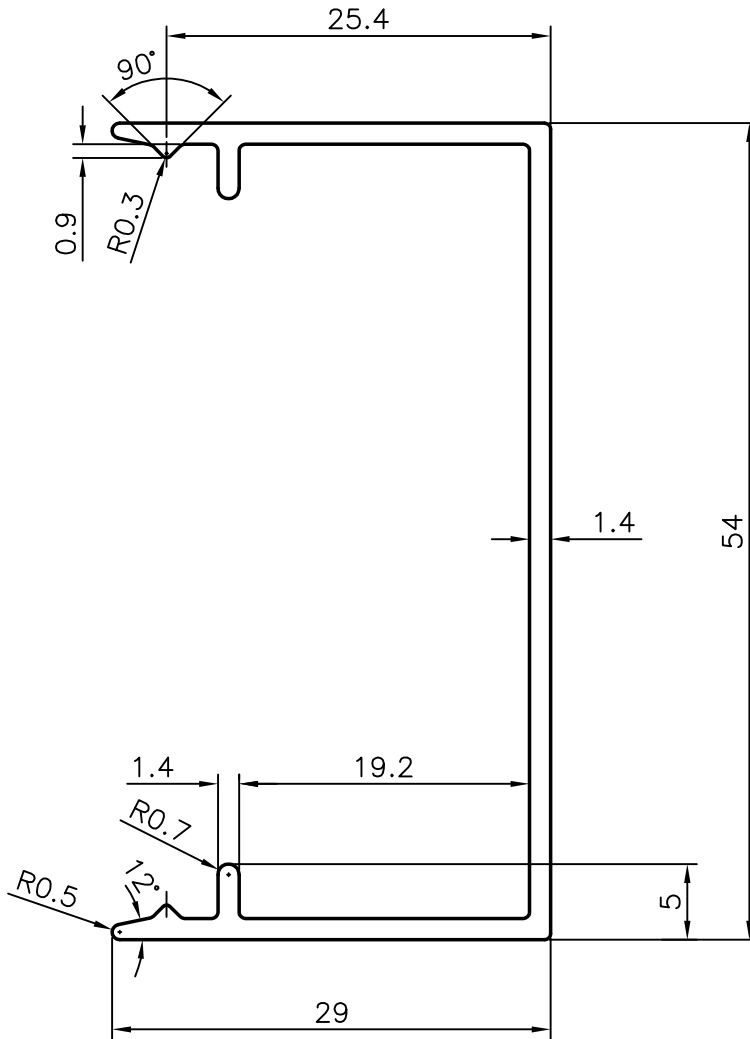

GENERAL WALL THICKNESS = 1.4 mm



 SYMBOL OF QUALITY AN ISO 9001 COMPANY	<b>JINDAL ALUMINIUM LTD.</b> BANGALORE-560073 (INDIA)	NAME		DATE	
		DRAWN	MALINGAPPA	04-11-2003	
		CHECKED			
APPROVED					
1. ALL DIMENSIONS ARE IN mm. 2. ROUND OFF ALL SHARP CORNERS WITH 0.40 mm. 3. TOLERANCES WILL BE AS PER BS:1474-1987 UNLESS OTHERWISE SPECIFIED		SCALE		2:1	
		AREA mm <sup>2</sup>		163.5	
		PERIMETER mm.		232.8	
PARTY'S NAME		DIPLOMAT SYSTEMS LTD.		WEIGHT kg/m	0.441
PARTY'S DRAWING No.		CW 2150		DRAWING No.	SECTION No.
ALLOY & TEMPER		HE9 WP		P-4554	-
DESCRIPTION		CURTAIN WALL SECTION		2990	2990
				22729	22729