

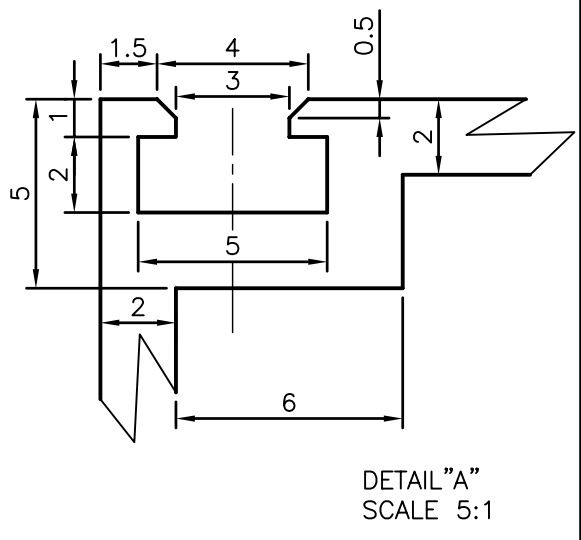

P-4771-1
 14637
 22739

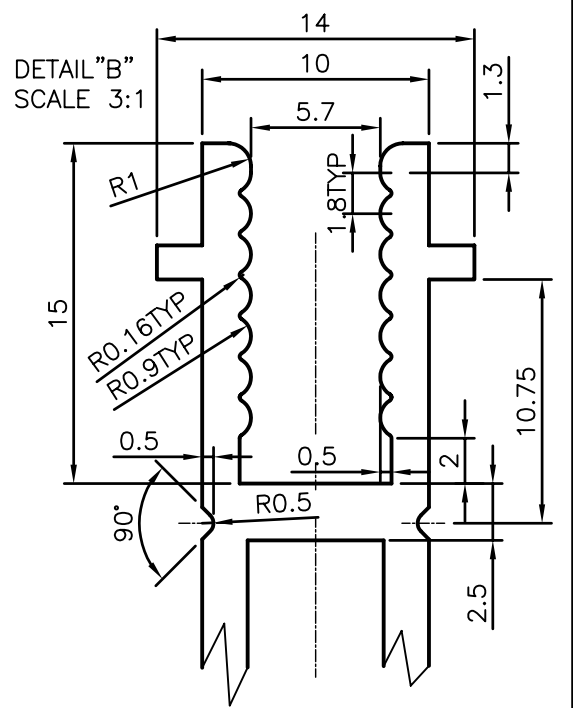
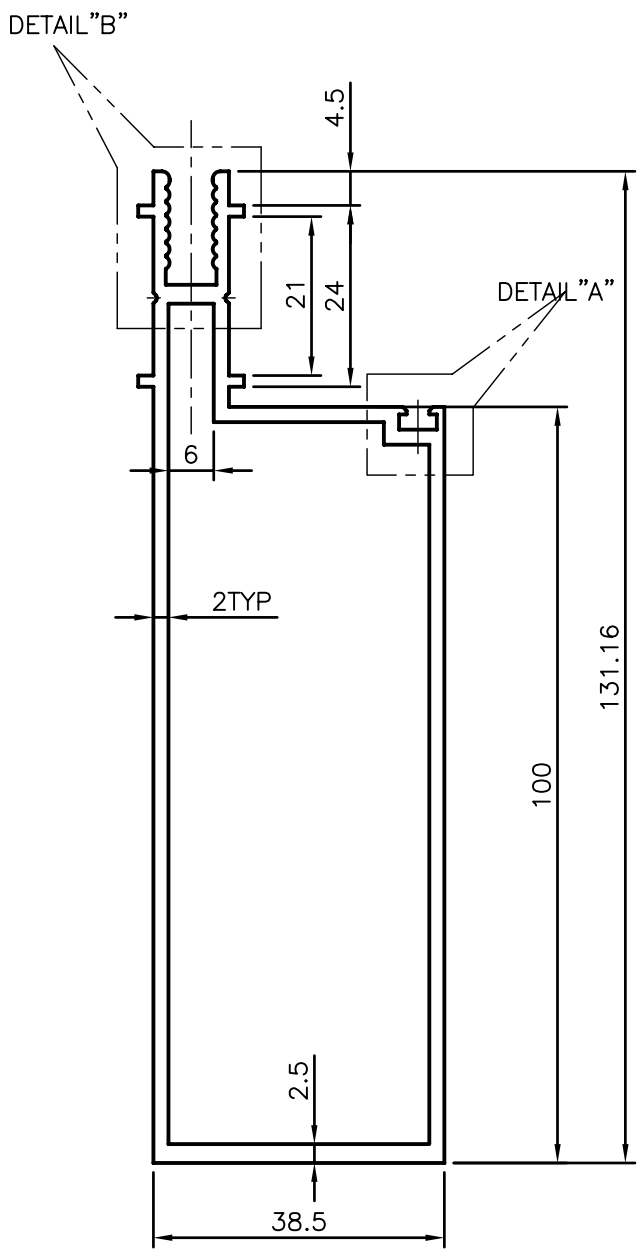

GENERAL WALL THICKNESS = 2.00mm

 SYMBOL OF QUALITY AN ISO 9002 COMPANY	JINDAL ALUMINIUM LTD. BANGALORE-560073 (INDIA)	NAME	DATE
		DRAWN	RAGHAVENDRA 09-03-2004
		CHECKED	
		APPROVED	
1. ALL DIMENSIONS ARE IN mm. 2. ROUND OFF ALL SHARP CORNERS WITH 0.40 mm. 3. TOLERANCES WILL BE AS PER IS:6477-1983 UNLESS OTHERWISE SPECIFIED		SCALE	1:1
		AREA mm ²	696.649
		PERIMETER mm.	400.205
		WEIGHT kg/m	1.881
PARTY'S NAME	GENERAL CATEGORY ,, DELHI MARKET	DRAWING No.	SECTION No.
PARTY'S DRAWING No.	AS PER DRAWING	P-4771-1	-
ALLOY & TEMPER	HE9 WP	14637	14637
		22739	22739
DESCRIPTION	CURTAIN WALL SECTION		