

P-5522

22754

**DETAIL-A**  
4:1

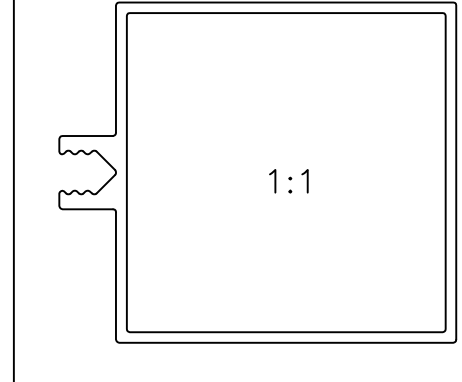
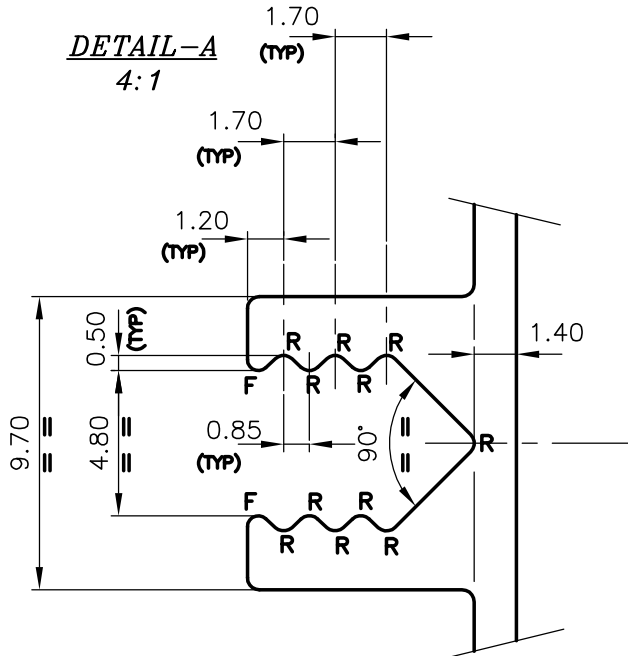

NOTE:-

- 1.R=0.4 RADII(11-PLCS)
- 2.F=FULL RADII(2-PLCS)

"A"

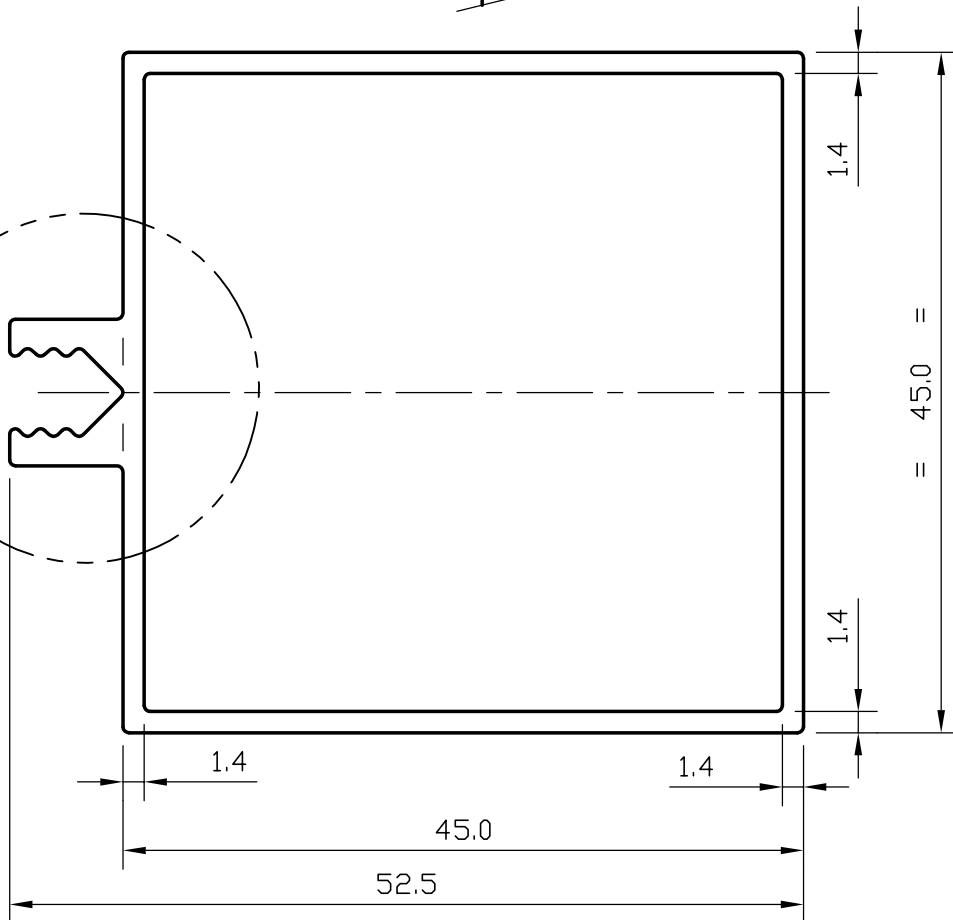

AVERAGE WEIGHT:- 2.800 Kg/3658 mm



SYMBOL OF QUALITY  
AN ISO 9001 COMPANY

**JINDAL ALUMINIUM LTD.**  
BANGALORE-560073 (INDIA)

	NAME	DATE
DRAWN	MALINGAPPA	26-05-2005
CHECKED		
APPROVED		
SCALE	2:1	
AREA mm <sup>2</sup>	283.319	
PERIMETER mm.	207.719	
WEIGHT kg/m	0.765	
DRAWING No.	SECTION No.	
P-5522	-	
22754	22754	

1. ALL DIMENSIONS ARE IN mm.
2. ROUND OFF ALL SHARP CORNERS WITH 0.40 mm.
3. TOLERANCES WILL BE AS PER IS:6477-1983 UNLESS OTHERWISE SPECIFIED

PARTY'S NAME	GENERAL CATEGORY, HYDERABAD MARKET
PARTY'S DRAWING No.	LIGHTER OF SECTION NO. 22717
ALLOY & TEMPER	HE9 WP
DESCRIPTION	CURTAIN WALL SECTION