

P-4410

S1046

22769



1:1

PLEASE INSURE THAT THIS PROFILE SHOULD FIT IN TO  
SEC. NO. 4563 BY SNAP FITTING, NOT BY SLIDING METHOD.

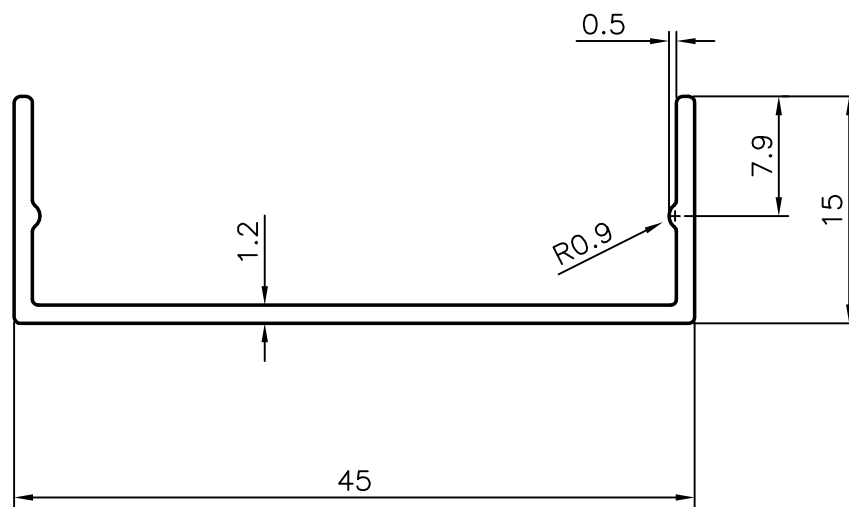

SYMBOL OF QUALITY  
AN ISO 9002 COMPANY

**JINDAL ALUMINIUM LTD.**  
BANGALORE-560073 (INDIA)

DRAWN	NAME	DATE
	MALINGAPPA	06-09-03

CHECKED		
APPROVED		

SCALE	2:1
-------	-----

AREA mm <sup>2</sup>	90
----------------------	----

PERIMETER mm.	148.2
---------------	-------

WEIGHT kg/m	0.243
-------------	-------

DRAWING No.	SECTION No.
P-4410	-
S1046	S1046
22769	22769

1. ALL DIMENSIONS ARE IN mm.
2. ROUND OFF ALL SHARP CORNERS WITH 0.40 mm.
3. TOLERANCES WILL BE AS PER IS: 3965-1981 UNLESS OTHERWISE SPECIFIED

PARTY'S NAME	LIKPROOF INDIA PVT. LTD., MUMBAI
--------------	----------------------------------

PARTY'S DRAWING No.	AS PER SPECIFICATION
---------------------	----------------------

ALLOY & TEMPER	HE9, WP
----------------	---------

DESCRIPTION	ARCHITECTURAL SECTION
-------------	-----------------------