

P-6220-2
22777

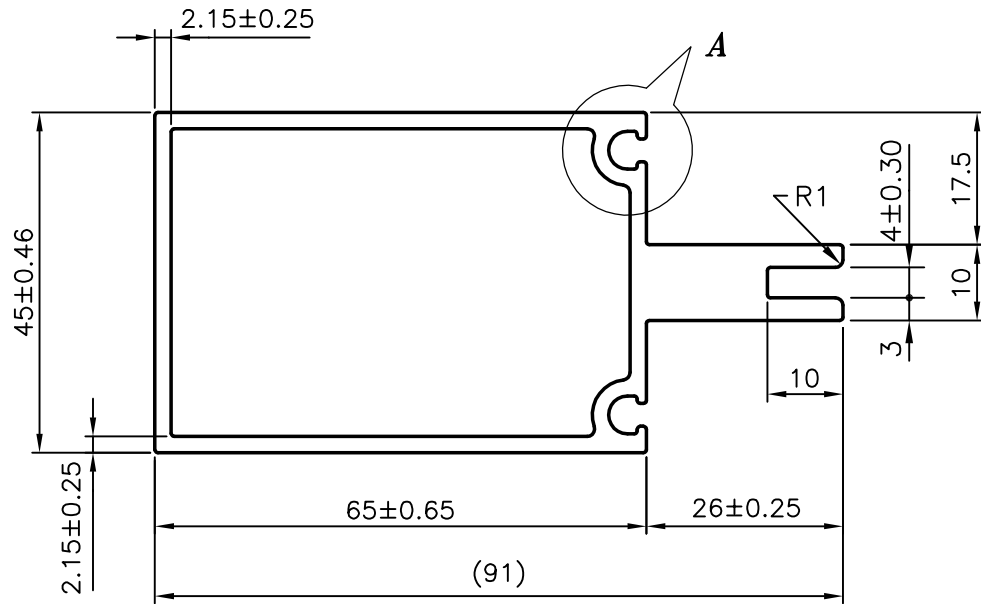
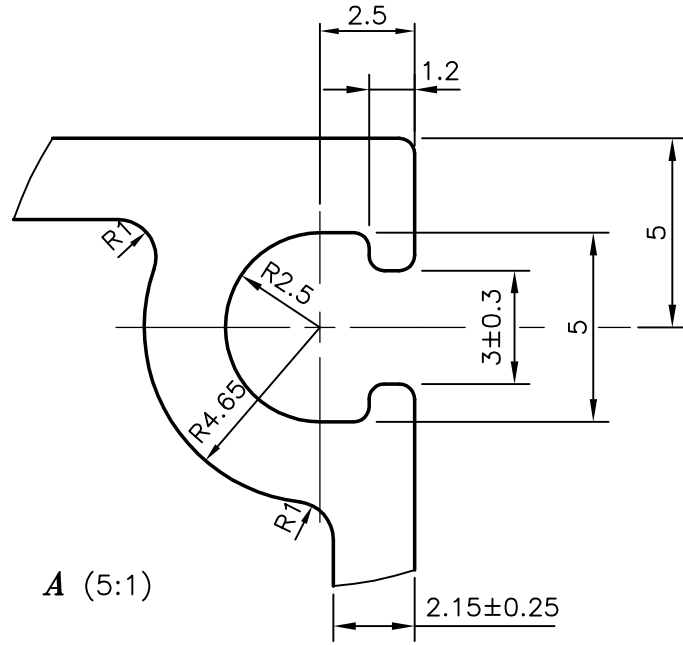

JINDAL ALUMINIUM LTD.
BANGALORE-560073 (INDIA)

	NAME	DATE
DRAWN	MALINGAPPA	25-03-2006
CHECKED		
APPROVED		

1. ALL DIMENSIONS ARE IN mm.
2. ROUND OFF ALL SHARP CORNERS WITH 0.40 mm.
3. TOLERANCES WILL BE AS PER IS:6477-1983 UNLESS OTHERWISE SPECIFIED

SCALE	1:1
AREA mm ²	699.558
PERIMETER mm.	311.073
WEIGHT kg/m	1.889

PARTY'S NAME	GENERAL CATEGORY, AHMEDABAD MARKET
PARTY'S DRAWING No.	AS PER SKETCH AND REQUIREMENT
ALLOY & TEMPER	HE9 WP
DESCRIPTION	CURTAIN WALL SECTION

DRAWING No.	SECTION No.
P-6220-2	-
22777	22777