

P-6692-1

22795

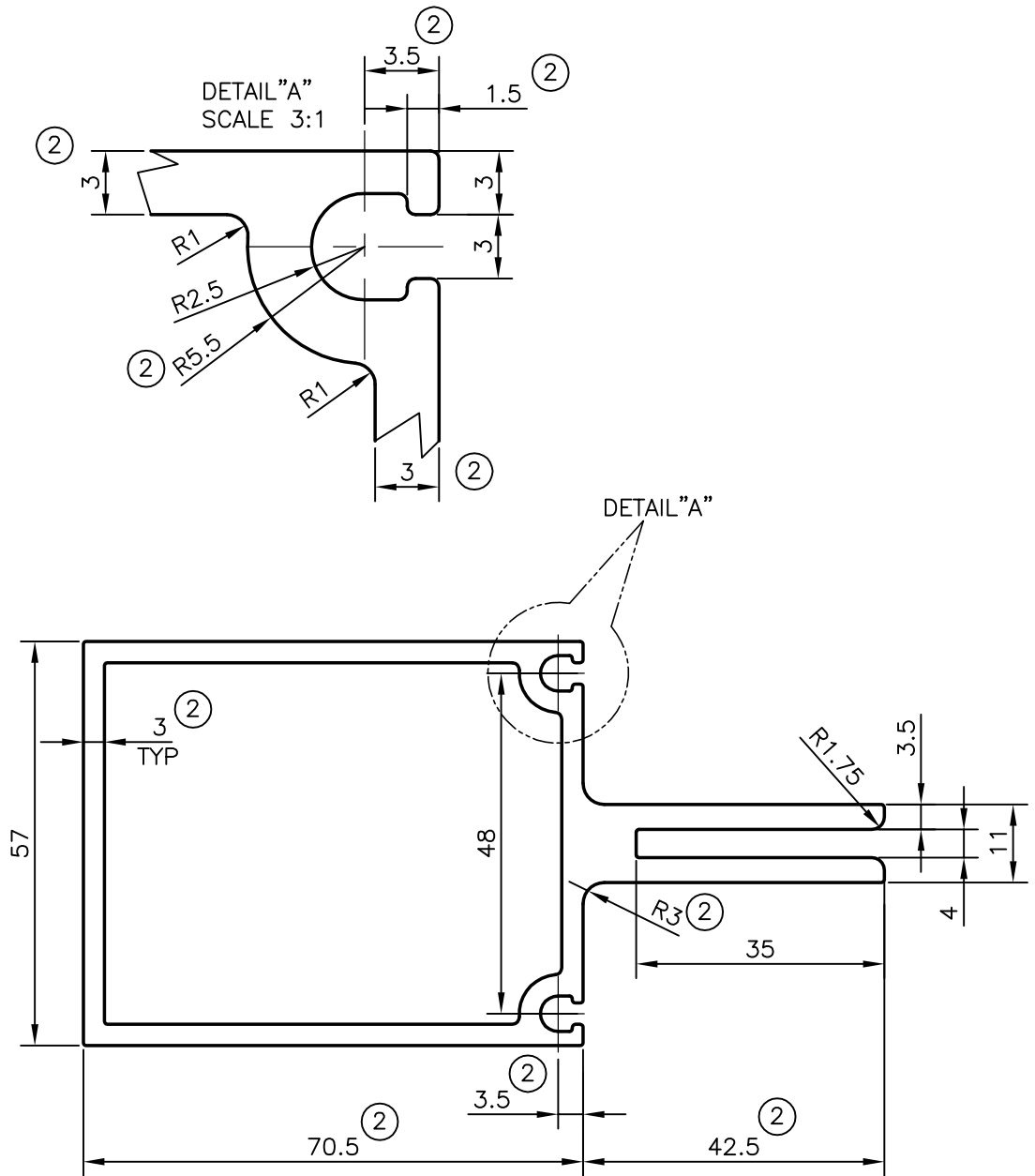

ISSUE-2 DIMENSIONS CHANGED FROM
WALL THICKNESS 2.00 TO 3.00mm

70.00 TO 70.50

43.00 TO 42.50

03.00 TO 03.50

01.00 TO 01.50

R3 ADDED

WEIGHT ALSO CHANGED FROM

2.285kg/M TO 2.921kg/M

GENERAL WALL THICKNESS = 3.00mm



SYMBOL OF QUALITY
AN ISO 9001 COMPANY

JINDAL ALUMINIUM LTD.
BANGALORE-560073 (INDIA)

	NAME	DATE
DRAWN	RAGHAVENDRA	16-10-2006
CHECKED		
APPROVED		

1. ALL DIMENSIONS ARE IN mm.
2. ROUND OFF ALL SHARP CORNERS WITH 0.25 mm.
3. TOLERANCES WILL BE AS PER IS:6477-1983 UNLESS OTHERWISE SPECIFIED

SCALE	1:1
AREA mm ²	1082.005
PERIMETER mm.	430.197
WEIGHT kg/m	2.921

PARTY'S NAME	GENERAL CATEGORY, COCHIN MARKET	DRAWING No.	P-6692-1	SECTION No.	-
PARTY'S DRAWING No.	AS PER SKETCH & AS PER REQUIREMENT	22795	22795-ISSUE-2		
ALLOY & TEMPER	HE9 WP				
DESCRIPTION	CURTAIN WALL SECTION				