

P-6893

22797

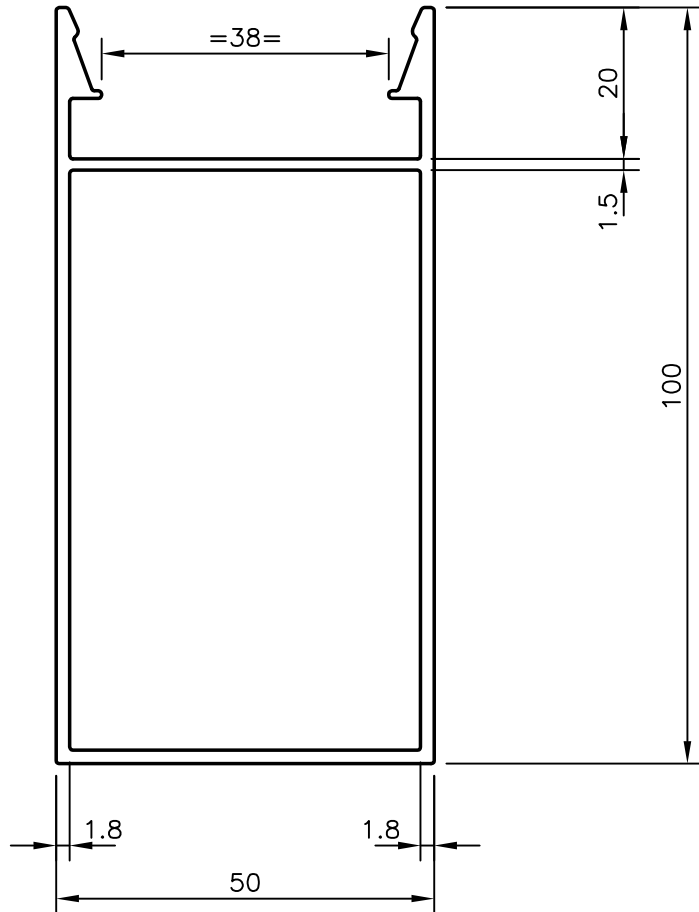

GENERAL WALL THICKNESS :- 1.80 mm

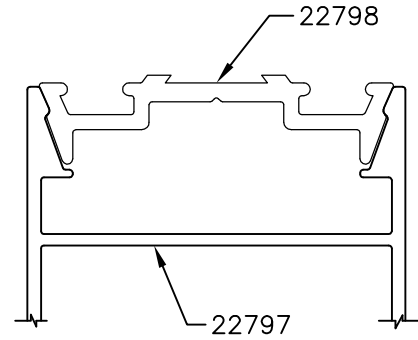
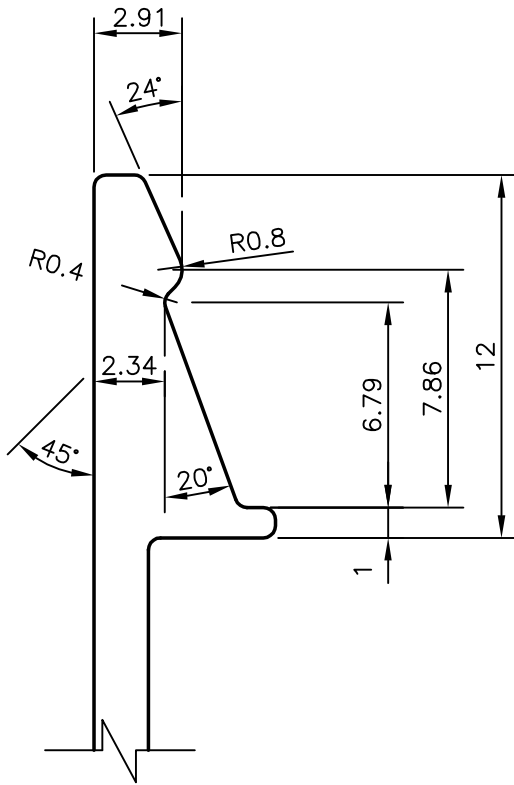

SYMBOL OF QUALITY
AN ISO 9002 COMPANY

JINDAL ALUMINIUM LTD.
BANGALORE-560073 (INDIA)

	NAME	DATE
DRAWN	J.P.KAUSHIK	07-12-2006
CHECKED		
APPROVED		
SCALE		1:1
AREA mm ²		549.957
PERIMETER mm.		349.88
WEIGHT kg/m		1.485
DRAWING No.	SECTION No.	
P-6893	-	
22797	22797	

1. ALL DIMENSIONS ARE IN mm.
2. ROUND OFF ALL SHARP CORNERS WITH 0.40 mm.
3. TOLERANCES WILL BE AS PER IS:6477-1983 UNLESS OTHERWISE SPECIFIED

PARTY'S NAME	GENERAL CATEGORY, MUMBAI MARKET
PARTY'S DRAWING No.	AS PER DRAWING
ALLOY & TEMPER	HE9 WP
DESCRIPTION	COVER PLATE SECTION