

P-6879

22800

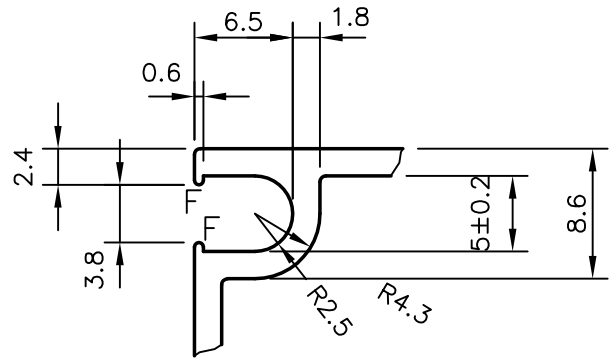
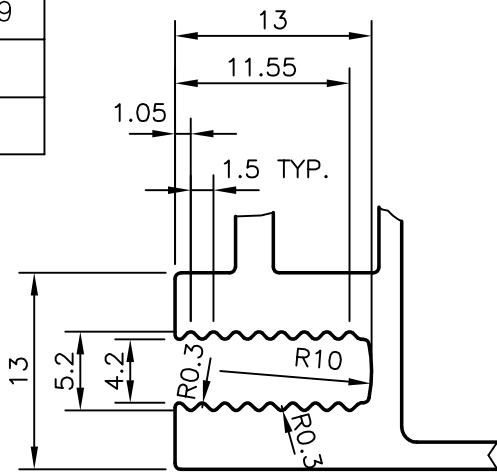

**DETAIL 'A'**  
(2:1)

**DETAIL 'B'**  
(2:1)

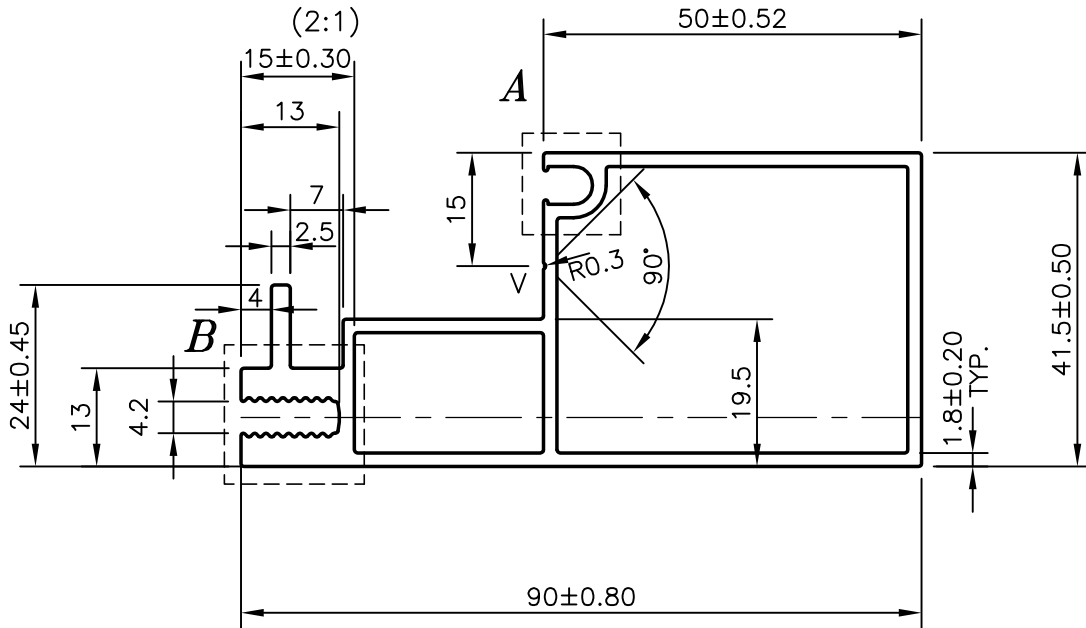

1. UNSPECIFIED WALL THICKNESS:-  $1.80 \pm 0.20$  mm.
2. F = FULL RADIUS (4)
3. V =  $0.30 \times 90^\circ$  VEE GROOVE



SYMBOL OF QUALITY  
AN ISO 9002 COMPANY

**JINDAL ALUMINIUM LTD.**  
BANGALORE-560073 (INDIA)

	NAME	DATE
DRAWN	J.P.KAUSHIK	14-12-2006
CHECKED		
APPROVED		

1. ALL DIMENSIONS ARE IN mm.
2. ROUND OFF ALL SHARP CORNERS WITH 0.40 mm.
3. TOLERANCES WILL BE AS PER IS:6477-1983 UNLESS OTHERWISE SPECIFIED

SCALE	1:1
AREA mm <sup>2</sup>	589.474
PERIMETER mm.	326.803
WEIGHT kg/m	1.592

PARTY'S NAME	GENERAL CATEGORY, BANGALORE MARKET	DRAWING No.	P-6879	SECTION No.	-
PARTY'S DRAWING No.	AS PER SAMPLE		22800		22800
ALLOY & TEMPER	HE9 WP				
DESCRIPTION	CURTAIN WALL SECTION				