

P-7028

22813

-

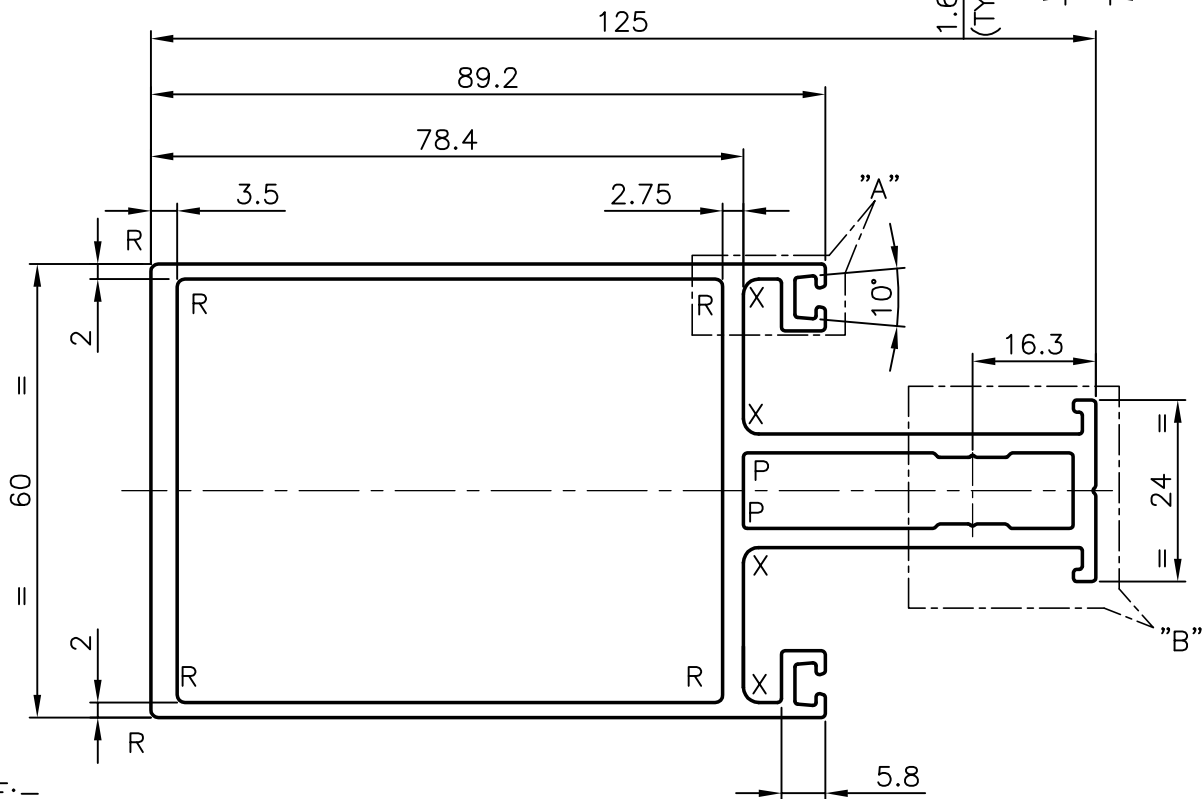
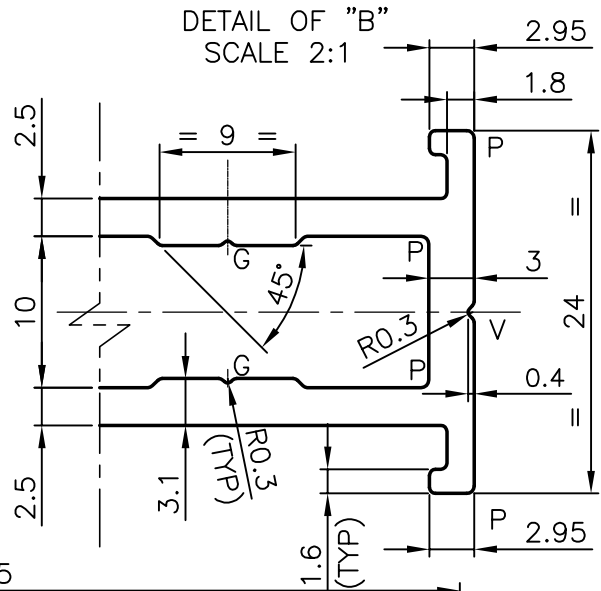
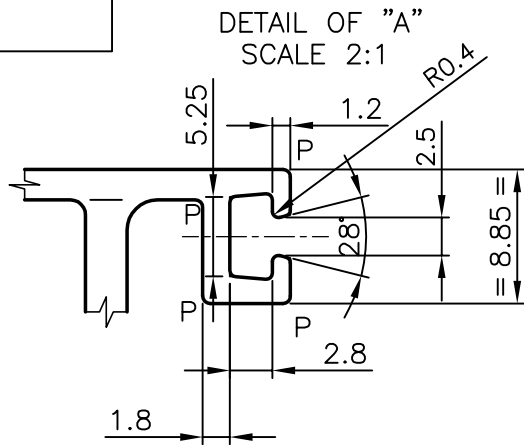

NOTE:-

1. R = R1.0 mm (6 PLACES)
2. X = R2.0 mm (4 PLACES)
3. P = R0.5 mm (14 PLACES)
4. V = 0.4x90° (1 PLACE)
5. G = 0.3x90° (2 PLACES)
6. UNSPECIFIED RADIUS = R0.4 mm



SYMBOL OF QUALITY
AN ISO 9001 COMPANY

JINDAL ALUMINIUM LTD.
BANGALORE-560073 (INDIA)

	NAME	DATE
DRAWN	PRASANNA.H.	15-02-2007
CHECKED		
APPROVED		
SCALE		1:1
AREA mm ²		1046.831
PERIMETER mm.		480.561
WEIGHT kg/m		2.826
DRAWING No.	SECTION No.	
P-7028	-	
22813	22813	
-	-	

1. ALL DIMENSIONS ARE IN mm.
2. ROUND OFF ALL SHARP CORNERS WITH 0.40 mm.
3. TOLERANCES WILL BE AS PER IS:6477-1983 UNLESS OTHERWISE SPECIFIED

PARTY'S NAME	GENERAL CATEGORY, MUMBAI MARKET
PARTY'S DRAWING No.	EXT-46-R1
ALLOY & TEMPER	HE9 WP
DESCRIPTION	CURTAIN WALL SECTION