

P-7029

22814

-

DETAIL OF "A"  
SCALE 3:1

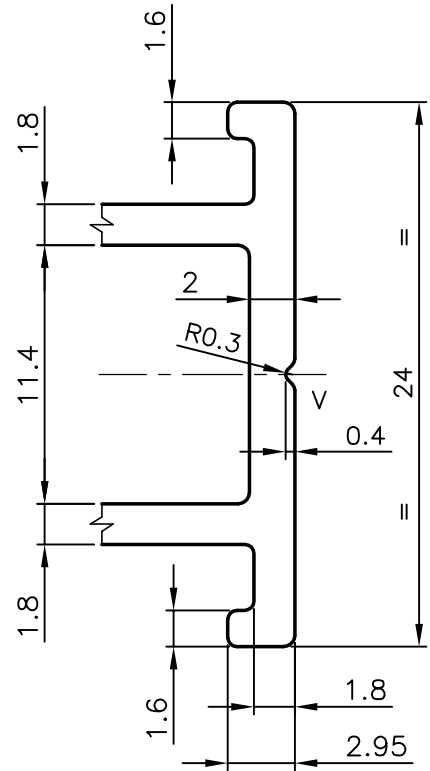
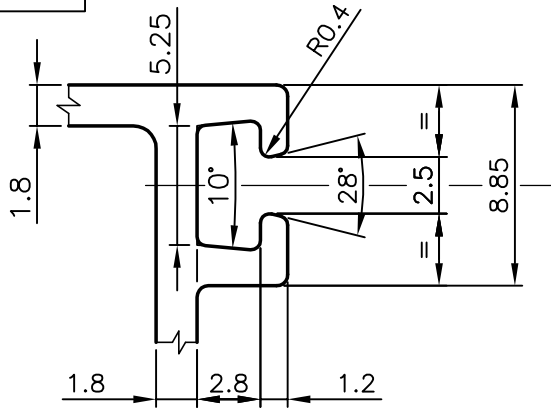

DETAIL OF "B"  
SCALE 3:1

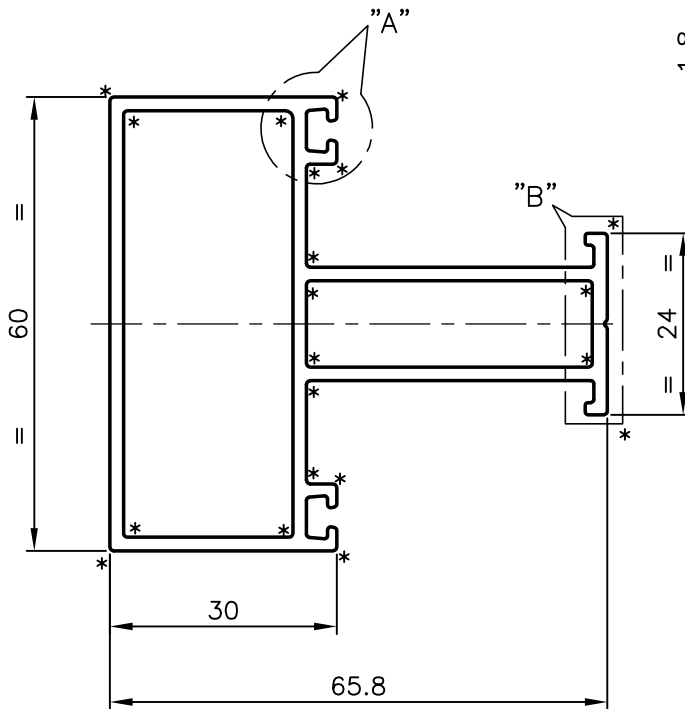

NOTE:-

1. \* = R0.5 mm (20 PLACES)
2. V = 0.4x90° (1 PLACE)
3. UNSPECIFIED RADIUS = R0.4 mm
4. GENERAL WALL THICKNESS = 1.80 mm



SYMBOL OF QUALITY  
AN ISO 9001 COMPANY

**JINDAL ALUMINIUM LTD.**  
BANGALORE-560073 (INDIA)

	NAME	DATE
DRAWN	PRASANNA.H.	15-02-2007
CHECKED		
APPROVED		
SCALE		1:1
AREA mm <sup>2</sup>		516.526
PERIMETER mm.		311.424
WEIGHT kg/m		1.395
DRAWING No.		SECTION No.
P-7029		-
22814		22814
-		-

1. ALL DIMENSIONS ARE IN mm.
2. ROUND OFF ALL SHARP CORNERS WITH 0.40 mm.
3. TOLERANCES WILL BE AS PER IS:6477-1983 UNLESS OTHERWISE SPECIFIED

PARTY'S NAME	GENERAL CATEGORY, MUMBAI MARKET
PARTY'S DRAWING No.	EXT-48-r2
ALLOY & TEMPER	HE9 WP
DESCRIPTION	CURTAIN WALL SECTION