

P-7030

22815

-

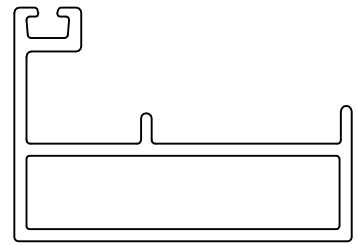

SCALE 1:1

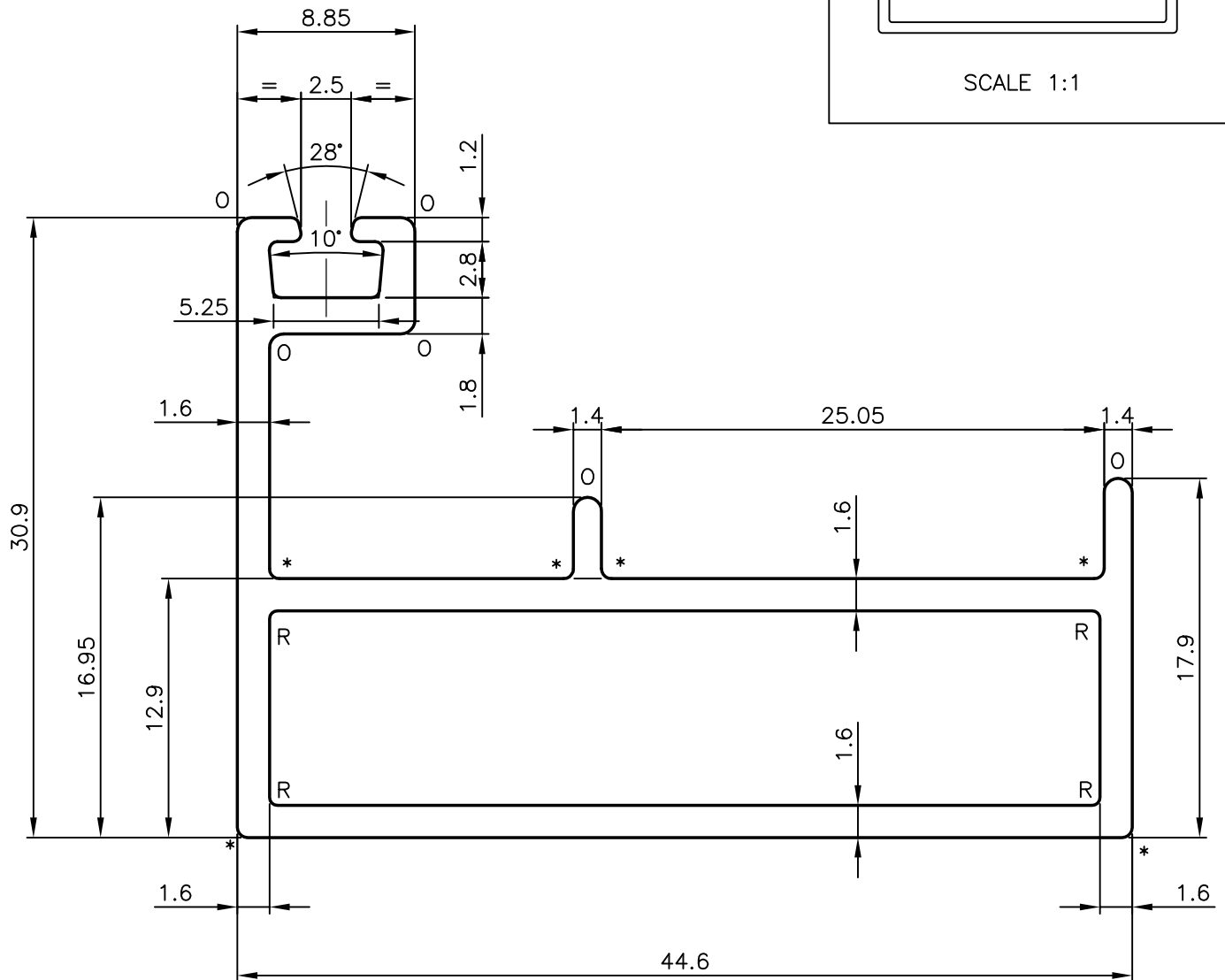

NOTE:-

1. R = R0.4 mm (4 PLACES)
2. O = R0.7 mm (6 PLACES)
3. * = R0.5 mm (6 PLACES)
4. GENERAL WALL THICKNESS = 1.6 mm



SYMBOL OF QUALITY
AN ISO 9001 COMPANY

JINDAL ALUMINIUM LTD.
BANGALORE-560073 (INDIA)

	NAME	DATE
DRAWN	PRASANNA.H.	15-02-2007
CHECKED		
APPROVED		

1. ALL DIMENSIONS ARE IN mm.
2. ROUND OFF ALL SHARP CORNERS WITH 0.50 mm.
3. TOLERANCES WILL BE AS PER IS:6477-1983 UNLESS OTHERWISE SPECIFIED

SCALE	3:1
AREA mm ²	238.4
PERIMETER mm.	192.36
WEIGHT kg/m	0.644

PARTY'S NAME	GENERAL CATEGORY, MUMBAI MARKET	DRAWING No.	P-7030	SECTION No.	-
PARTY'S DRAWING No.	EXT-47-R1		22815		22815
ALLOY & TEMPER	HE9 WP		-		-
DESCRIPTION	CURTAIN WALL SECTION				