

P-7057-2

22826

MATCHING SECTION



22826 SCALE 1:1

DETAIL OF "A"
SCALE 3:1

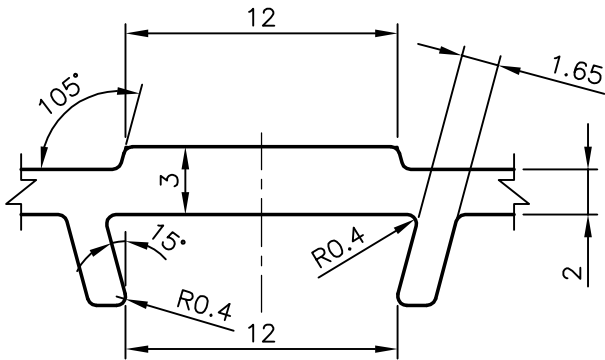

DETAIL OF "B"
SCALE 3:1

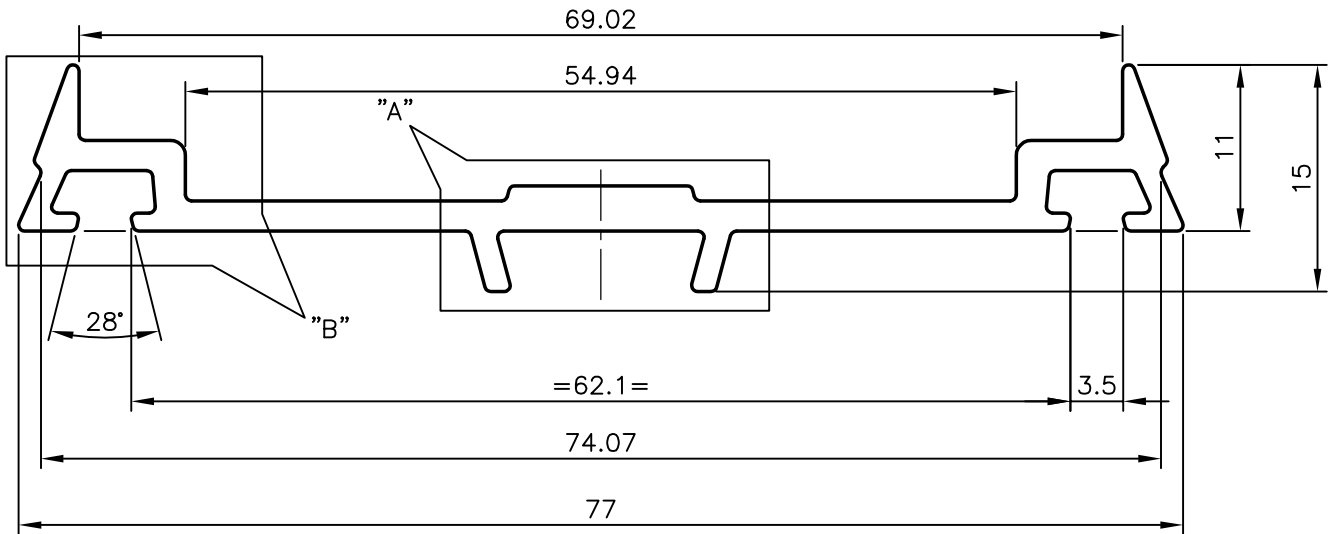
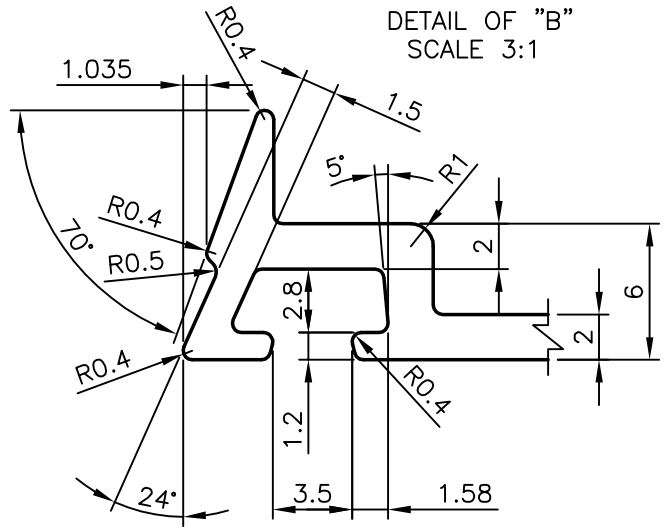

SYMBOL OF QUALITY
AN ISO 9001 COMPANY

JINDAL ALUMINIUM LTD.
BANGALORE-560073 (INDIA)

	NAME	DATE
DRAWN	PRASANN.H	07-06-2007
CHECKED		
APPROVED		

1. ALL DIMENSIONS ARE IN mm.
2. ROUND OFF ALL SHARP CORNERS WITH 0.40 mm.
3. TOLERANCES WILL BE AS PER IS:3965-1981 UNLESS OTHERWISE SPECIFIED

SCALE	2:1
AREA mm ²	228.998
PERIMETER mm.	227.418
WEIGHT kg/m	0.618

PARTY'S NAME	GENERAL CATEGORY, MUMBAI MARKET	DRAWING No.	P-7057-2	SECTION No.	-
PARTY'S DRAWING No.	EXT-42-R1		22826		22826
ALLOY & TEMPER	HE9 WP				
DESCRIPTION	CURTAIN WALL SECTION				