

P-7248
S1994
22827

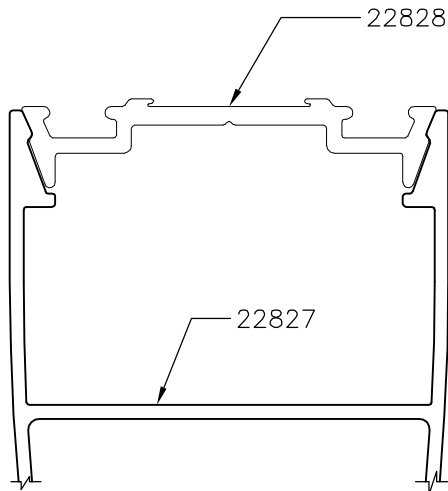

AFTER EXTRUSION, MANUALLY TO MAINTAIN 58 mm DIMENSION ON MINUS SIDE FOR PROPER FITMENT WITH SECTION No:-22828

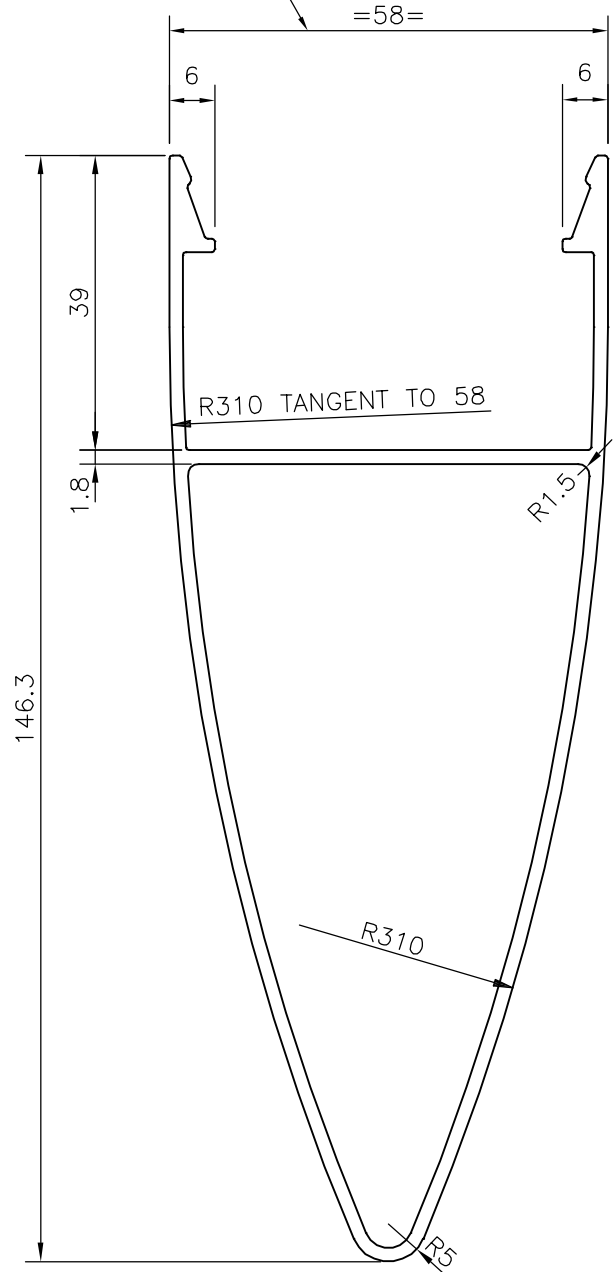
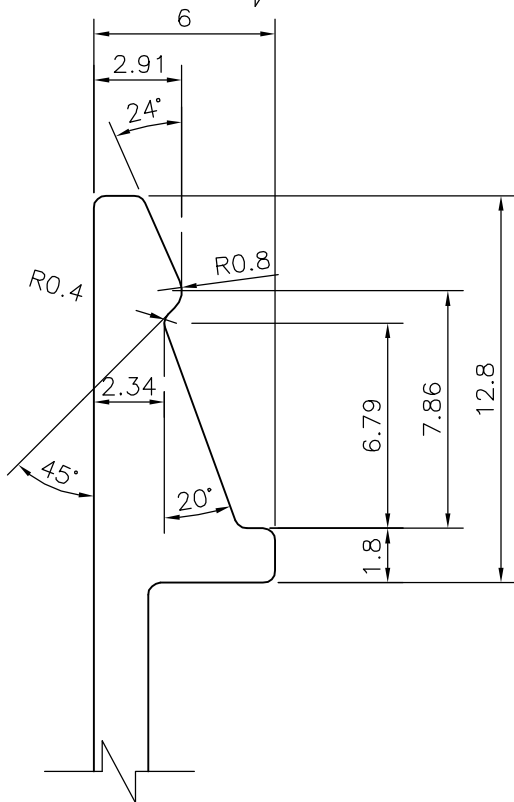

GENERAL WALL THICKNESS 1.80 mm



SYMBOL OF QUALITY
AN ISO 9001 COMPANY

JINDAL ALUMINIUM LTD.
BANGALORE-560073 (INDIA)

	NAME	DATE
DRAWN	J.P.KAUSHIK	24-04-2007
CHECKED		
APPROVED		
SCALE		1:1
AREA mm ²		684.376
PERIMETER mm.		450.148
WEIGHT kg/m		1.848
DRAWING No.	SECTION No.	
P-7248	-	
S1994	S1994	
22827	22827	

1. ALL DIMENSIONS ARE IN mm.
2. ROUND OFF ALL SHARP CORNERS WITH 0.40 mm.
3. TOLERANCES WILL BE AS PER IS:6477-1983 UNLESS OTHERWISE SPECIFIED

PARTY'S NAME	GLASSPAANE ALUMINIUM (INDIA) LTD., THANE
PARTY'S DRAWING No.	AS PER SAMPLE & REQUIREMENT
ALLOY & TEMPER	HE9 WP
DESCRIPTION	COVER PLATE SECTION