

P-7249

S1995

22828

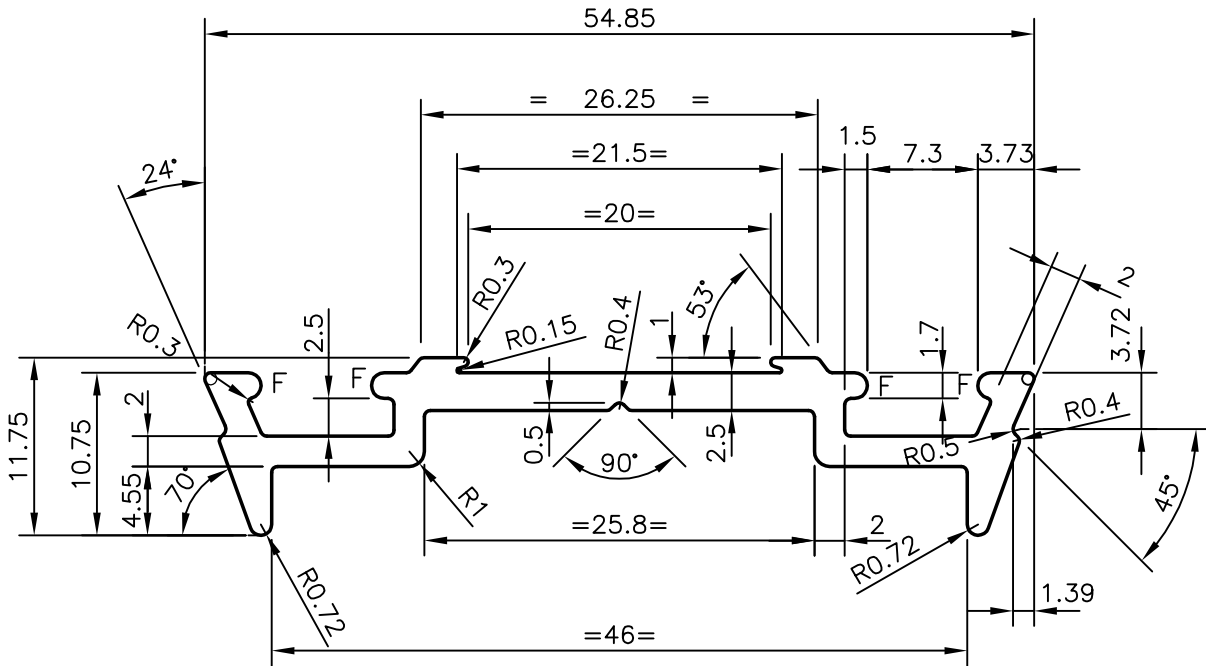
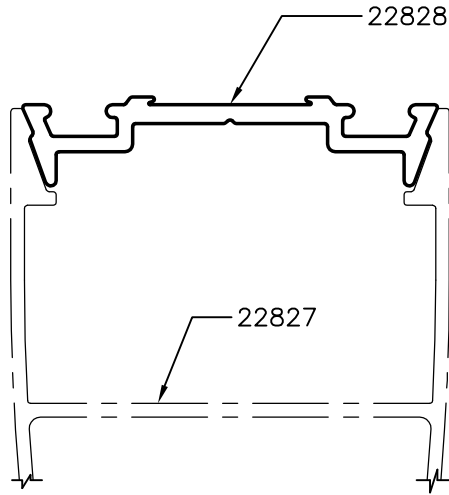
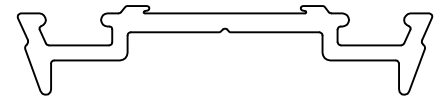

F= FULL RADIUS(4)



SYMBOL OF QUALITY  
AN ISO 9002 COMPANY

**JINDAL ALUMINIUM LTD.**  
BANGALORE-560073 (INDIA)

	NAME	DATE
DRAWN	J.P.KAUSHIK	24-04-2007
CHECKED		
APPROVED		
SCALE		2:1
AREA mm <sup>2</sup>		185.631
PERIMETER mm.		166.126
WEIGHT kg/m		0.501
DRAWING No.	SECTION No.	
P-7249	-	
S1995	S1995	
22828	22828	

1. ALL DIMENSIONS ARE IN mm.
2. ROUND OFF ALL SHARP CORNERS WITH 0.40 mm.
3. TOLERANCES WILL BE AS PER IS:3965-1981 UNLESS OTHERWISE SPECIFIED

PARTY'S NAME	GLASSPAANE ALUMINIUM (INDIA) LTD., THANE
PARTY'S DRAWING No.	AS PER REQUIREMENT
ALLOY & TEMPER	HE9 WP
DESCRIPTION	PRESSURE PLATE SECTION