

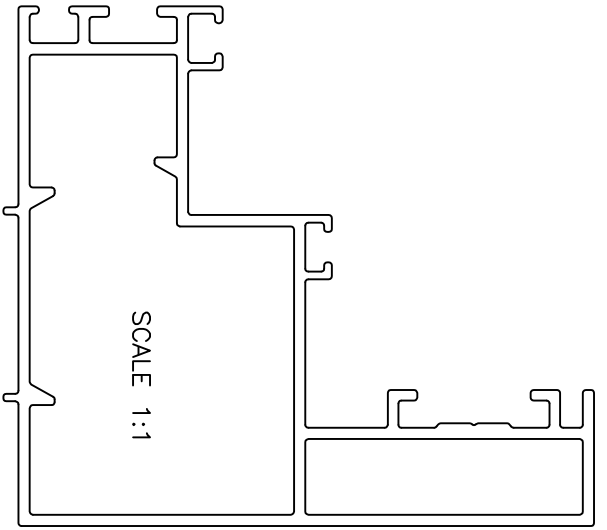

P-7489

22830

DETAIL OF "A"
SCALE 4:1

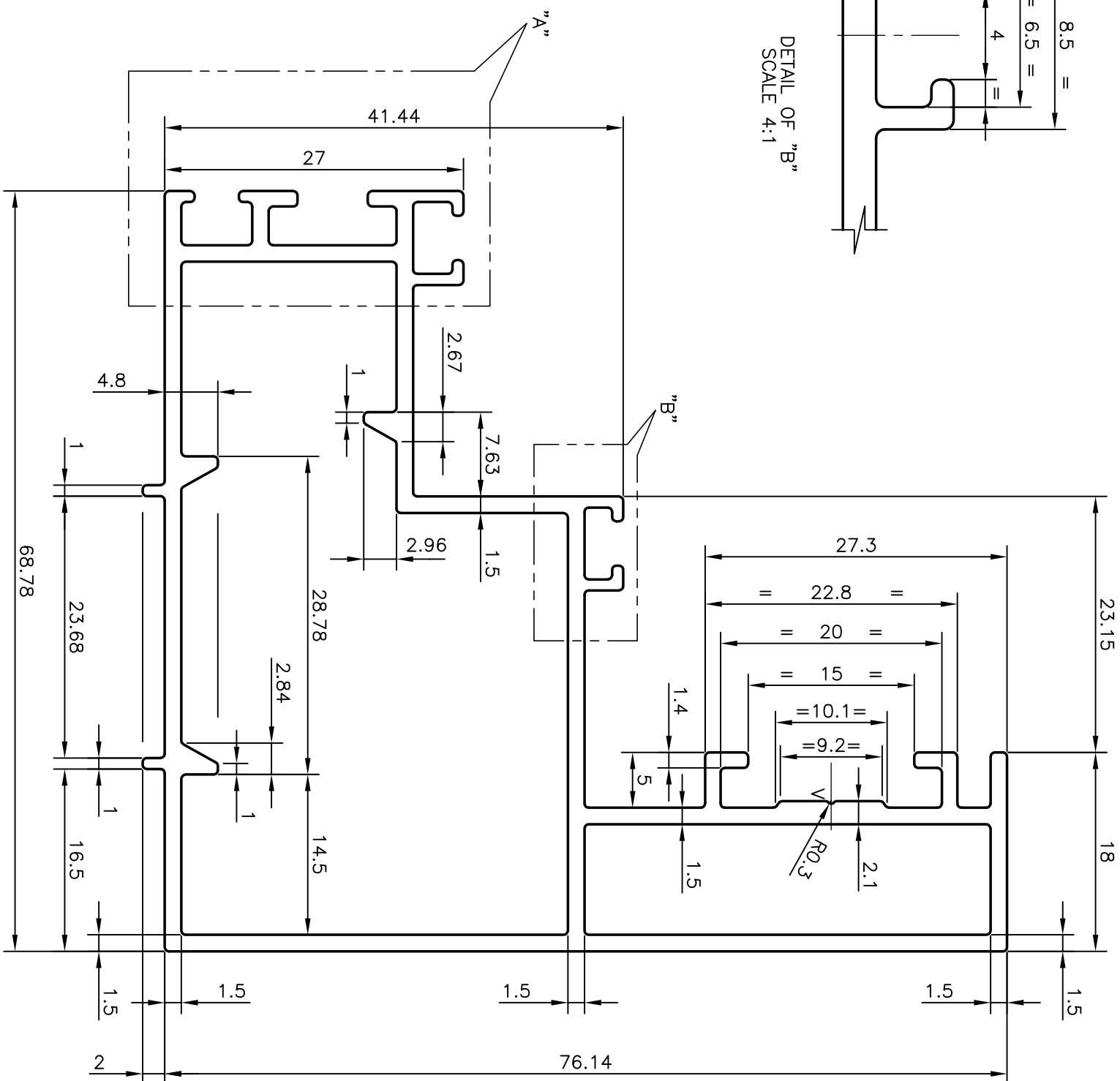
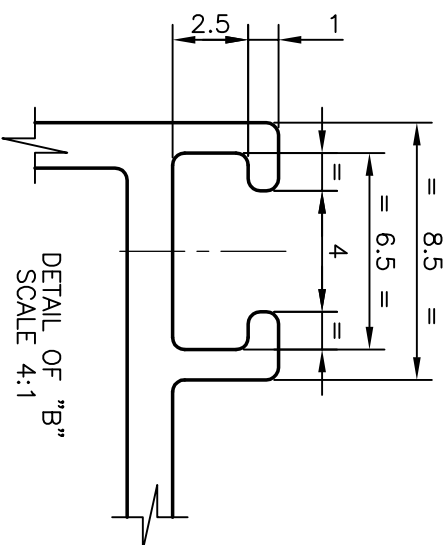
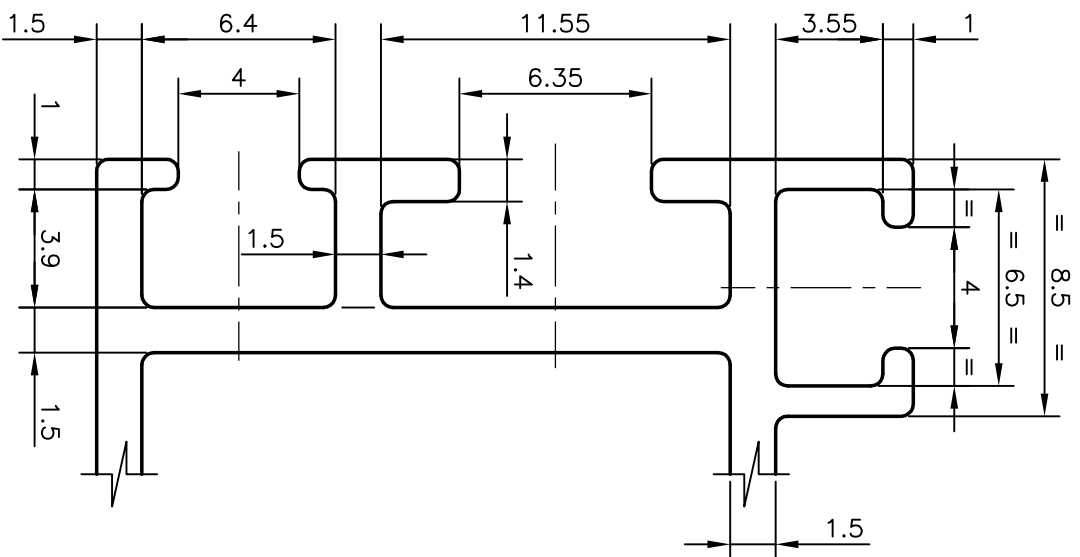

V = 'V'-GROOVE 0.30X90° (1 PLACE)

 <p>SYMBOL OF QUALITY AN ISO 9001 COMPANY</p>		<p>JINDAL ALUMINIUM LTD. BANGALORE-560073 (INDIA)</p>		NAME	DATE
				DRAWN	PRASANN. H
<p>1. ALL DIMENSIONS ARE IN mm. 2. ROUND OFF ALL SHARP CORNERS WITH 0.40 mm. 3. TOLERANCES WILL BE AS PER IS:6477-1983 UNLESS OTHERWISE SPECIFIED</p>		CHECKED			
<p>PARTY'S NAME MERINT INFRASTRUCTURE LTD., MUMBAI</p>		APPROVED			
<p>PARTY'S DRAWING No. MIL/DIE/OS/05A</p>		SCALE	2:1		
<p>ALLOY & TEMPER HE9 WP</p>		AREA mm ²	535.293		
<p>DESCRIPTION CURTAIN WALL-OPENABLE SASH SECTION</p>		PERIMETER mm.	404.14		
		WEIGHT kg/m	1.445		
		DRAWING No.	SECTION No.		
		P-7489	-		
		22830	22830		