

P-7550

22832

DETAIL OF "A"
SCALE 3:1

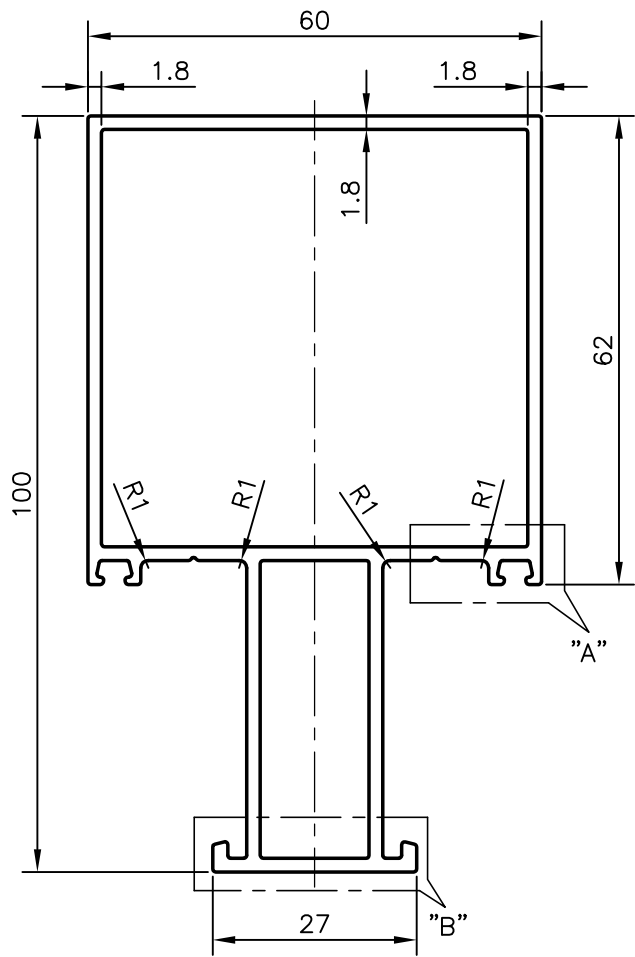
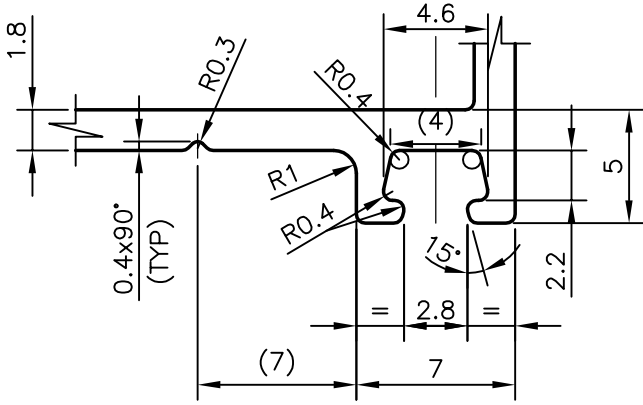

DETAIL OF "B"
SCALE 3:1

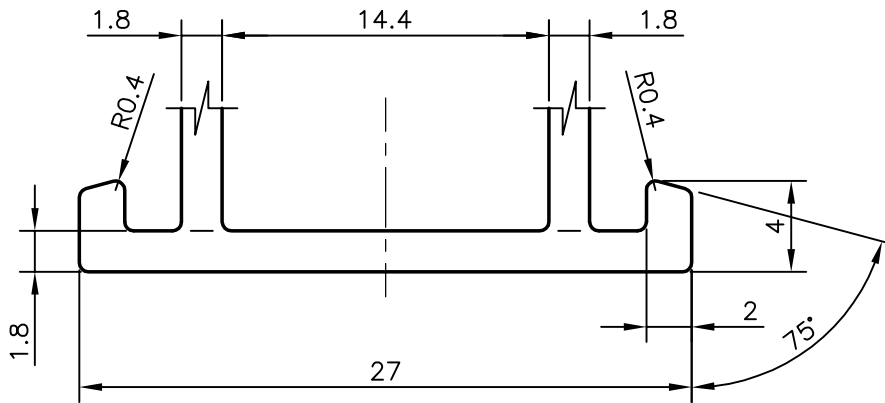

SYMBOL OF QUALITY
AN ISO 9001 COMPANY

JINDAL ALUMINIUM LTD.
BANGALORE-560073 (INDIA)

	NAME	DATE
DRAWN	PRASANN.H	12-10-2007
CHECKED		
APPROVED		

1. ALL DIMENSIONS ARE IN mm.
2. ROUND OFF ALL SHARP CORNERS WITH 0.40 mm.
3. TOLERANCES WILL BE AS PER IS:6477-1983 UNLESS OTHERWISE SPECIFIED

SCALE	1:1
AREA mm ²	633.817
PERIMETER mm.	371.114
WEIGHT kg/m	1.711

PARTY'S NAME	GLASSPAANE ALUMINIUM (INDIA) PVT. LTD., THANE
PARTY'S DRAWING No.	AL-170
ALLOY & TEMPER	HE9 WP
DESCRIPTION	CURTAIN WALL-TRANSOM SECTION

DRAWING No.	SECTION No.
P-7550	-
22832	22832