

P-7729

22840

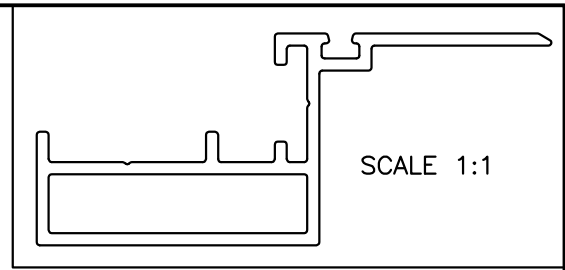

SCALE 1:1

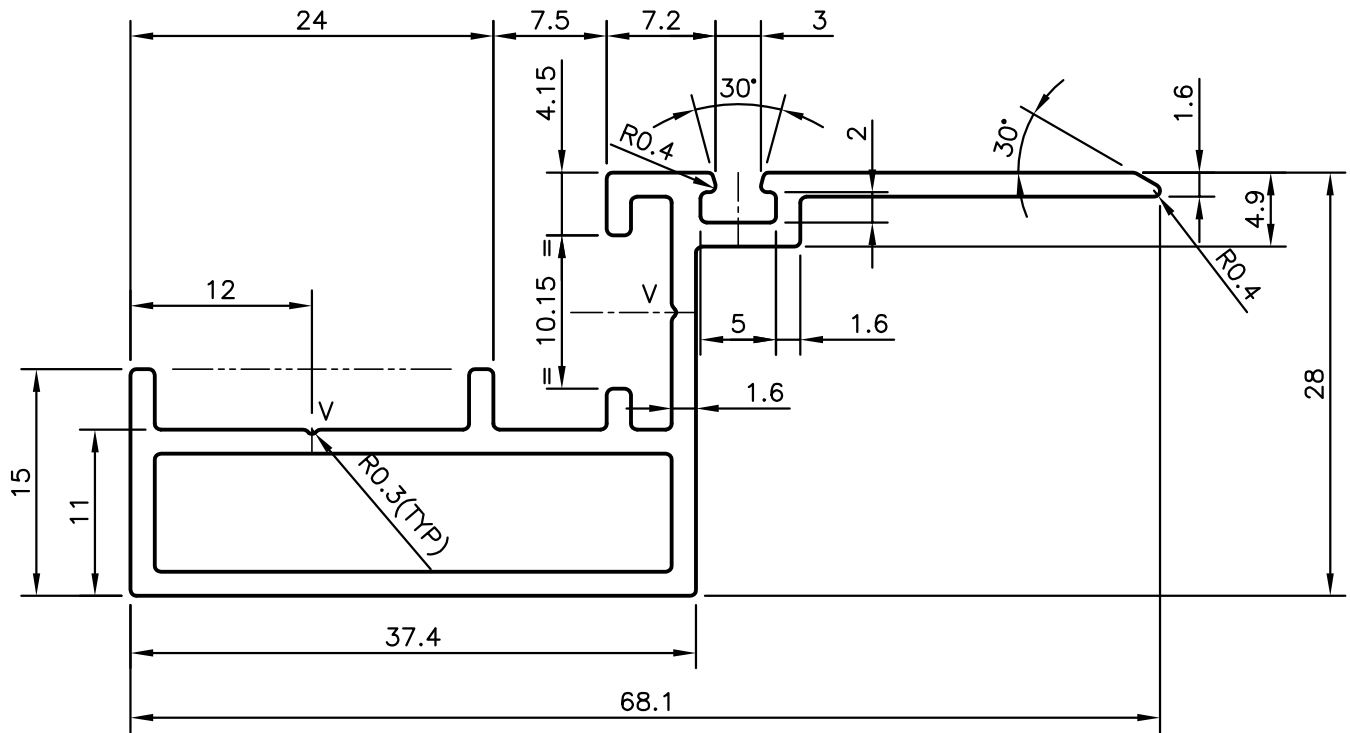

- 1. UNSPECIFIED WALL THICKNESS = 1.60 mm
- 2. V = 'V'-GROOVE 0.3x90° (2 PLACES)

 SYMBOL OF QUALITY AN ISO 9001 COMPANY	JINDAL ALUMINIUM LTD. BANGALORE-560073 (INDIA)	NAME		DATE
		DRAWN	PRASANN.H	08-12-2007
1. ALL DIMENSIONS ARE IN mm. 2. ROUND OFF ALL SHARP CORNERS WITH 0.40 mm. 3. TOLERANCES WILL BE AS PER IS:6477-1983 UNLESS OTHERWISE SPECIFIED		CHECKED		
		APPROVED		
PARTY'S NAME GENERAL CATEGORY, CHENNAI MARKET		SCALE		2:1
		AREA mm ²		256.626
PARTY'S DRAWING No. AS PER SAMPLE		PERIMETER mm.		231.964
		WEIGHT kg/m		0.693
ALLOY & TEMPER HE9 WP		DRAWING No.		SECTION No.
		P-7729		-
DESCRIPTION CURTAIN WALL SECTION		22840		22840