

P-7732

22843

DETAIL OF "A"  
SCALE 3:1

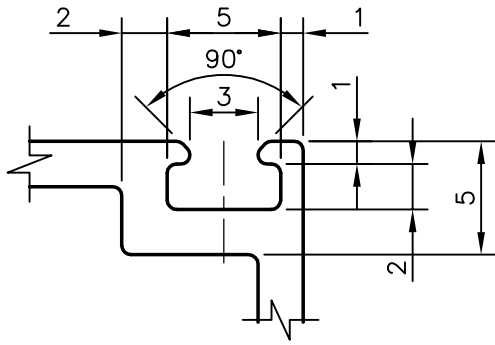

DETAIL OF "B"  
SCALE 3:1

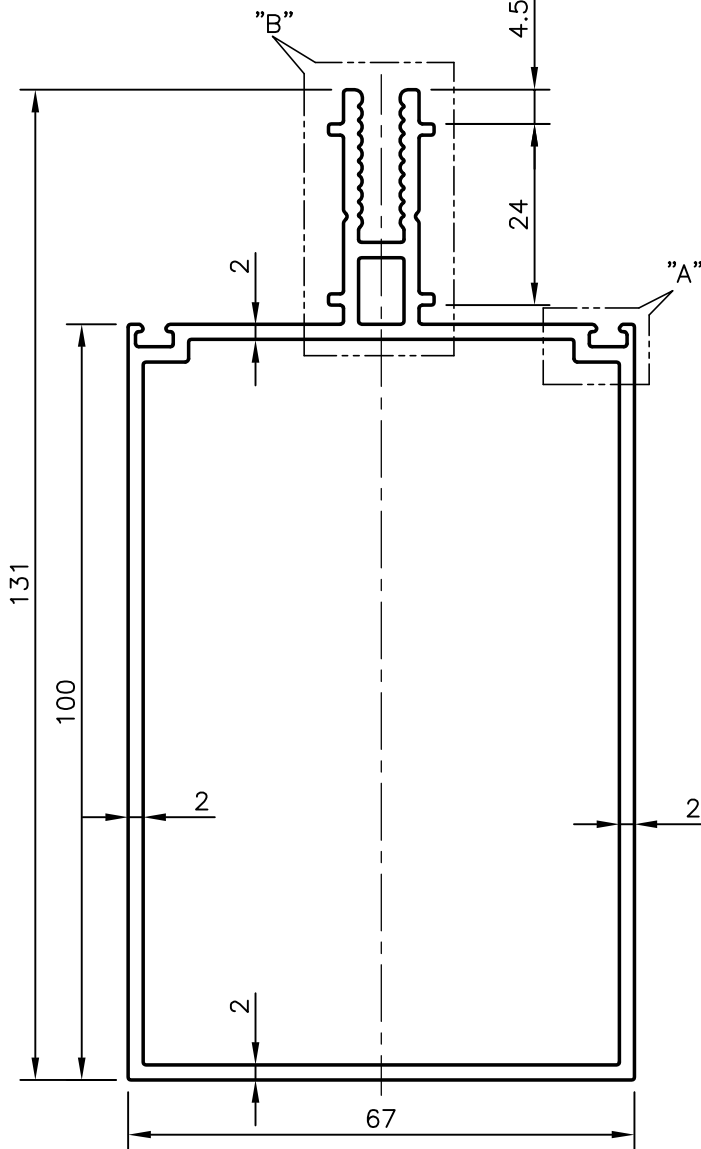
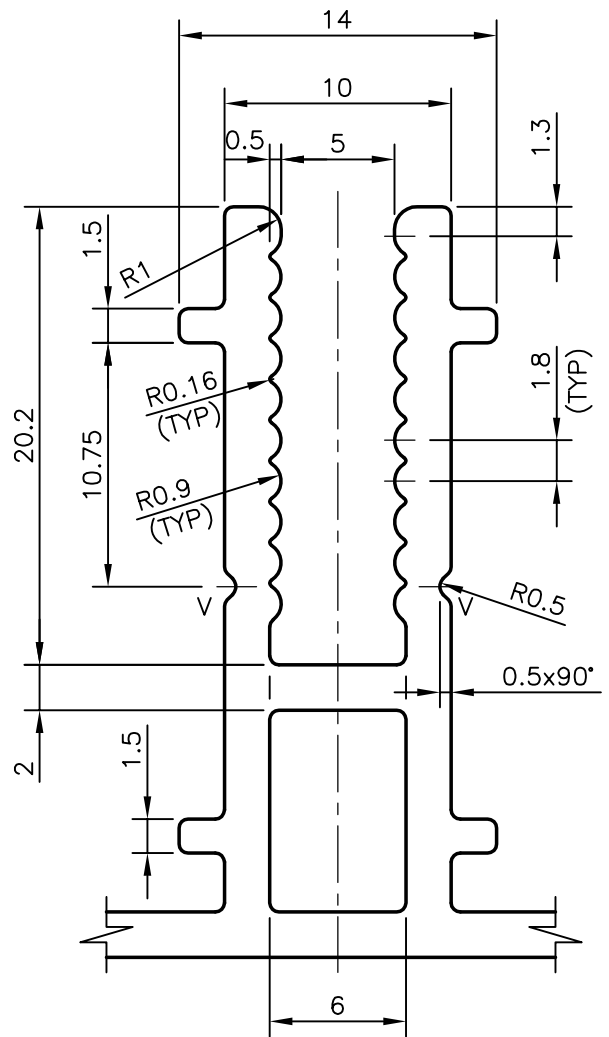

1. V = 'V'-GROOVE 0.5x90° (2 PLACES)



SYMBOL OF QUALITY  
AN ISO 9001 COMPANY

**JINDAL ALUMINIUM LTD.**  
BANGALORE-560073 (INDIA)

	NAME	DATE
DRAWN	PRASANN.H	08-12-2007
CHECKED		
APPROVED		
SCALE		1:1
AREA mm <sup>2</sup>		820.925
PERIMETER mm.		472.149
WEIGHT kg/m		2.216
DRAWING No.	SECTION No.	
P-7732	-	
22843	22843	

- ALL DIMENSIONS ARE IN mm.
- ROUND OFF ALL SHARP CORNERS WITH 0.40 mm.
- TOLERANCES WILL BE AS PER IS:6477-1983 UNLESS OTHERWISE SPECIFIED

PARTY'S NAME	GENERAL CATEGORY, CHENNAI MARKET
PARTY'S DRAWING No.	AS PER SAMPLE
ALLOY & TEMPER	HE9 WP
DESCRIPTION	CURTAIN WALL SECTION-VERTICAL MAIN MULLION