

P-7667

22845

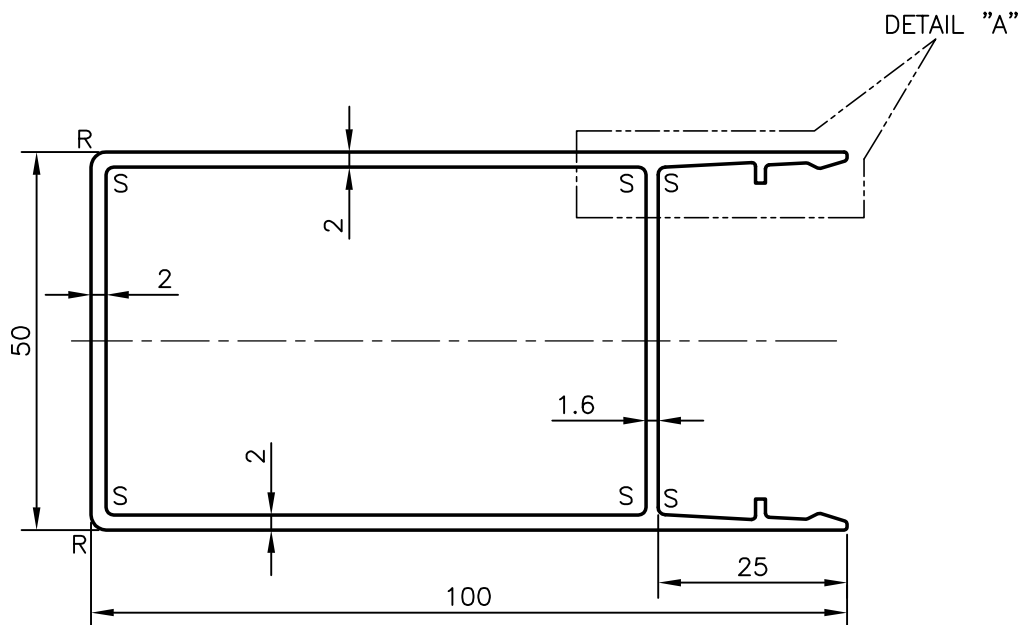

R = 2.00 mm RADIUS (2 PLACES)
 S = 1.00 mm RADIUS (6 PLACES)
 UNSPECIFIED RADIUS WILL BE 0.40mm

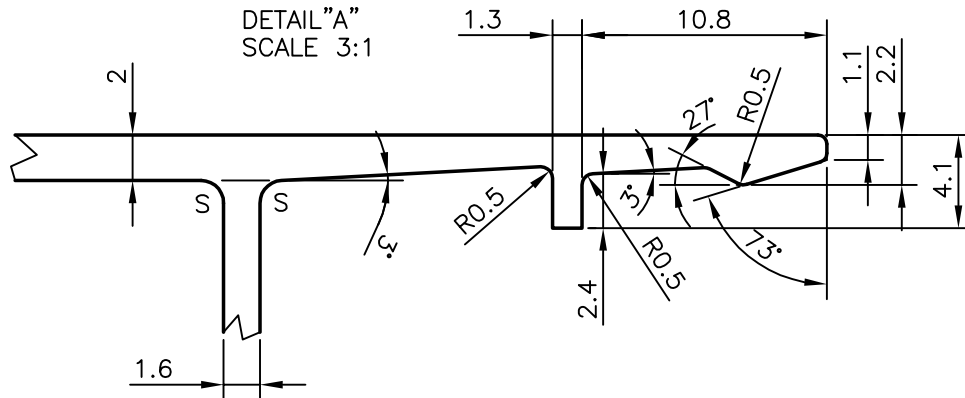

SYMBOL OF QUALITY
 AN ISO 9001 COMPANY

JINDAL ALUMINIUM LTD.
 BANGALORE-560073 (INDIA)

	NAME	DATE
DRAWN	RAGHAVENDRA	14-11-2007
CHECKED		
APPROVED		
SCALE		1:1
AREA mm ²		555.691
PERIMETER mm.		355.172
WEIGHT kg/m		1.500
DRAWING No.	SECTION No.	
P-7667	-	
22845	22845	

1. ALL DIMENSIONS ARE IN mm.
 2. ROUND OFF ALL SHARP CORNERS WITH 0.40 mm.
 3. TOLERANCES WILL BE AS PER IS:6477-1983 UNLESS OTHERWISE SPECIFIED

PARTY'S NAME	ORBIT CORPORATION LTD., MUMBAI
PARTY'S DRAWING No.	350-001-ELE-1
ALLOY & TEMPER	6063 T6
DESCRIPTION	CURTAIN WALL SECTION (MULLION)