

4893

22856

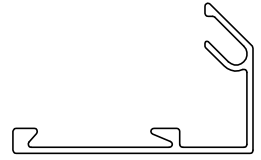

SCALE 1:1

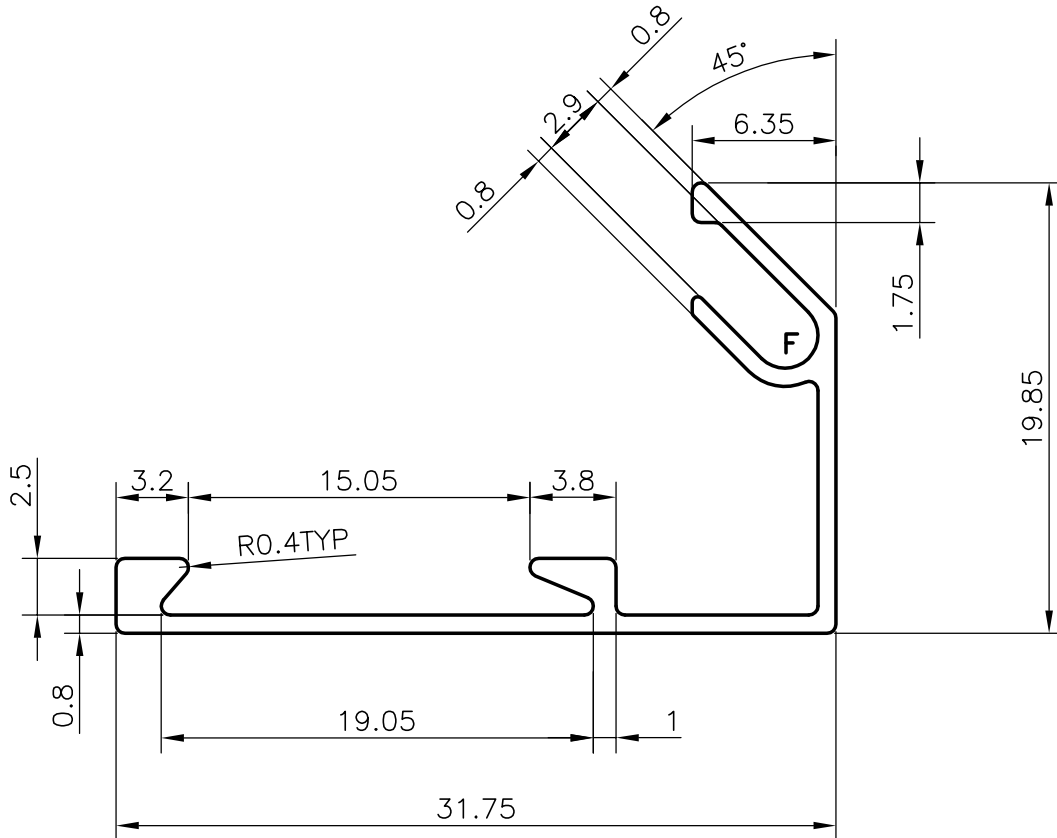

GENERAL WALL THICKNESS = 0.80mm

F = FULL RADII (1 PLACES)

NO OF PIECES IN 100 kgs:-165 (AVERAGE)



SYMBOL OF QUALITY  
AN ISO 9002 COMPANY

**JINDAL ALUMINIUM LTD.**  
BANGALORE-560073 (INDIA)

NAME DATE

DRAWN RAGHAVENDRA 10-10-01

CHECKED

APPROVED

SCALE 3:1 &amp; 1:1

WEIGHT kg/m 0.165

PERIMETER 135.19mm

SECTION No. 22856

DRAWING No. 22856

1. ALL DIMENSIONS ARE IN mm.
2. ROUND OFF ALL SHARP CORNERS WITH 0.40 mm.
3. TOLERANCES WILL BE AS PER I.S 3965-1981 UNLESS OTHERWISE SPECIFIED

PARTY'S NAME GENERAL CATEGORY ,. DELHI MARKET

PARTY'S DRAWING No. LIGHTER SECTION OF 4862

ALLOY &amp; TEMPER HE9 WP

DESCRIPTION ARCHITECTURAL SECTION