

4895

22858

SCALE 1:1

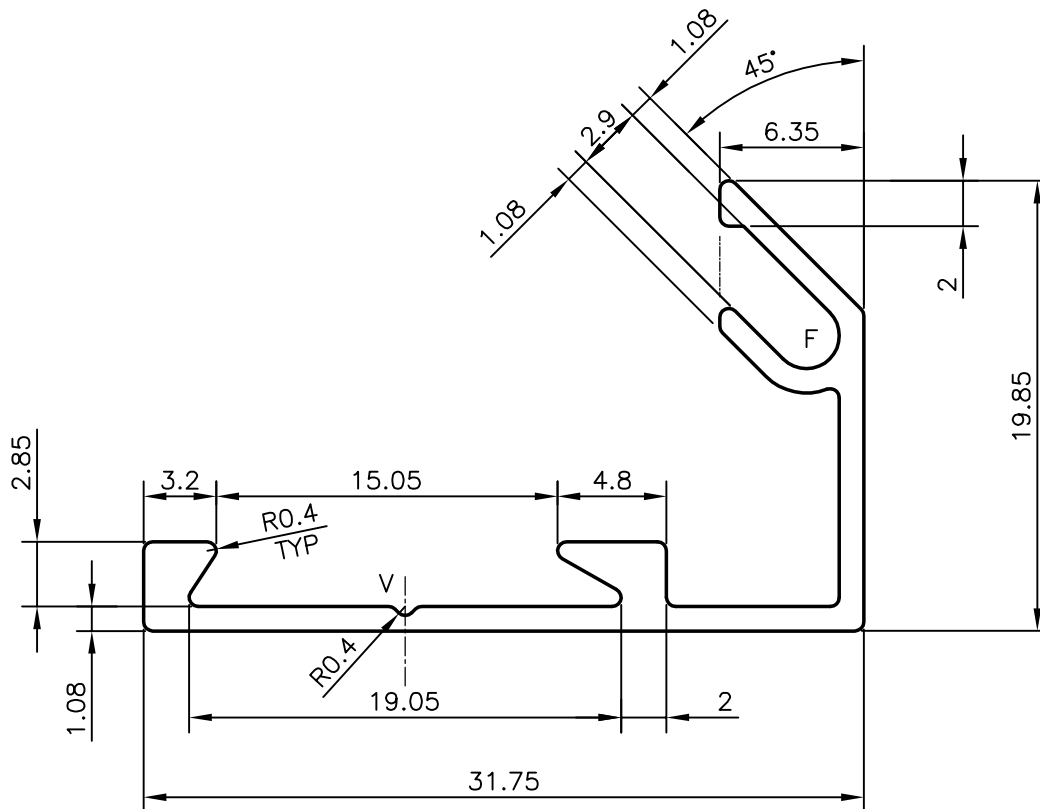
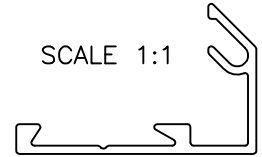

GENERAL WALL THICKNESS = 1.08mm

F = FULL RADII (1 PLACE)

V = VEE GROOVE 0.40x90° (1 PLACE)

NO. OF PIECES IN 100kgs = 125 (AVERAGE)



SYMBOL OF QUALITY
AN ISO 9001 COMPANY

JINDAL ALUMINIUM LTD.
BANGALORE-560073 (INDIA)

	NAME	DATE
DRAWN	RAGHAVENDRA	05-03-2007
CHECKED		
APPROVED		

1. ALL DIMENSIONS ARE IN mm.
2. ROUND OFF ALL SHARP CORNERS WITH 0.40 mm.
3. TOLERANCES WILL BE AS PER IS:3965-1981 UNLESS OTHERWISE SPECIFIED

SCALE	3:1
AREA mm ²	81.103
PERIMETER mm.	134.987
WEIGHT kg/m	0.219

PARTY'S NAME	-	DRAWING No.	4895	SECTION No.	4895
PARTY'S DRAWING No.	LIGHTER SECTION OF 4862		22858		22858
ALLOY & TEMPER	HE9 WP				
DESCRIPTION	ARCHITECTURAL SECTION				