

P-3585-2

S850

2996

22892

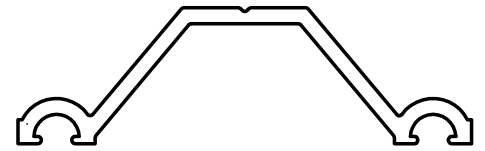

SCALE 1:1

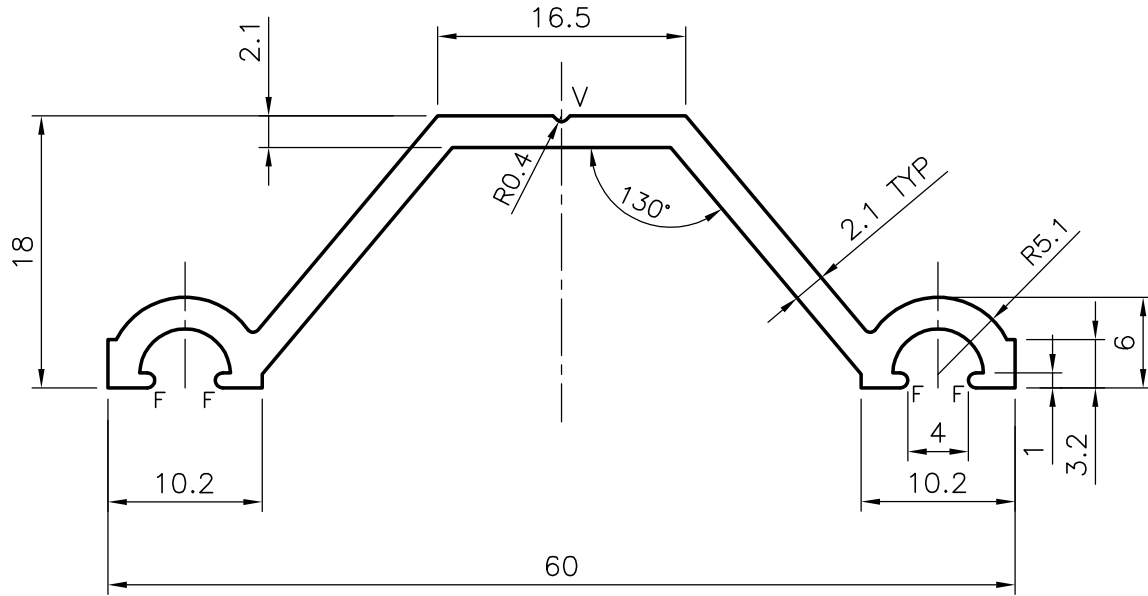

1. GENERAL WALL THICKNESS = 2.1mm
2. F = FULL RADII (4 PLACES)
3. V = 0.4x90° "V" GROOVE



SYMBOL OF QUALITY
AN ISO 9002 COMPANY

JINDAL ALUMINIUM LTD.
BANGALORE-560073 (INDIA)

	NAME	DATE
DRAWN	RAGHAVENDRA	22-01-02
CHECKED		
APPROVED		

1. ALL DIMENSIONS ARE IN mm.
2. ROUND OFF ALL SHARP CORNERS WITH 0.40 mm.
3. TOLERANCES WILL BE AS PER IS: 3965-1981 UNLESS OTHERWISE SPECIFIED

PARTY'S NAME	POLYKLAD INDIA ,. BANGALORE	SCALE	2:1 & 1:1
PARTY'S DRAWING No.	AS PER SAMPLE	WEIGHT kg/m	0.480
ALLOY & TEMPER	HE9 WP	PERIMETER	176.18mm
DESCRIPTION	ARCHITECTURAL MISC SECTION	SECTION No.	22892
		DRAWING No.	22892