

P-5475

22895

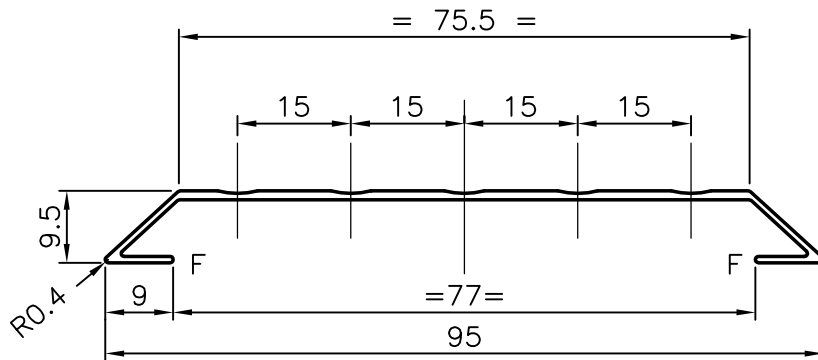
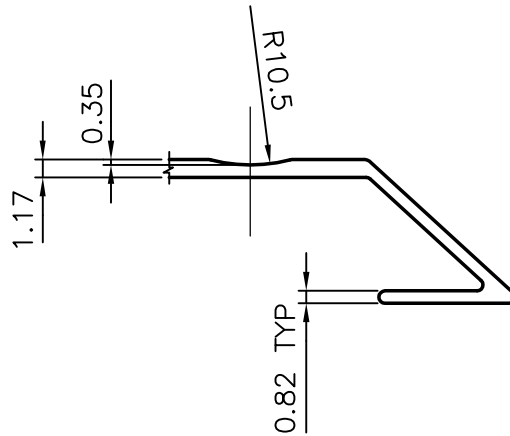

AVERAGE WEIGHT:- 1.152 kg/3658 mm

F = FULL RADIUS (2 PLACES)



SYMBOL OF QUALITY
AN ISO 9001 COMPANY

JINDAL ALUMINIUM LTD.
BANGALORE-560073 (INDIA)

	NAME	DATE
DRAWN	MALINGAPPA	03-05-2005
CHECKED		
APPROVED		
SCALE		1:1, 2:1
AREA mm ²		116.691
PERIMETER mm.		232.593
WEIGHT kg/m		0.315
DRAWING No.		SECTION No.
P-5475		-
22895		22895

1. ALL DIMENSIONS ARE IN mm.
2. ROUND OFF ALL SHARP CORNERS WITH 0.40 mm.
3. TOLERANCES WILL BE AS PER IS:3965-1981 UNLESS OTHERWISE SPECIFIED

PARTY'S NAME	GENERAL CATEGORY, KOLKATA MARKET
PARTY'S DRAWING No.	AS PER SAMPLE/WEIGHT
ALLOY & TEMPER	HE9 WP
DESCRIPTION	FOOT STEP SECTION