

P-5603

22896

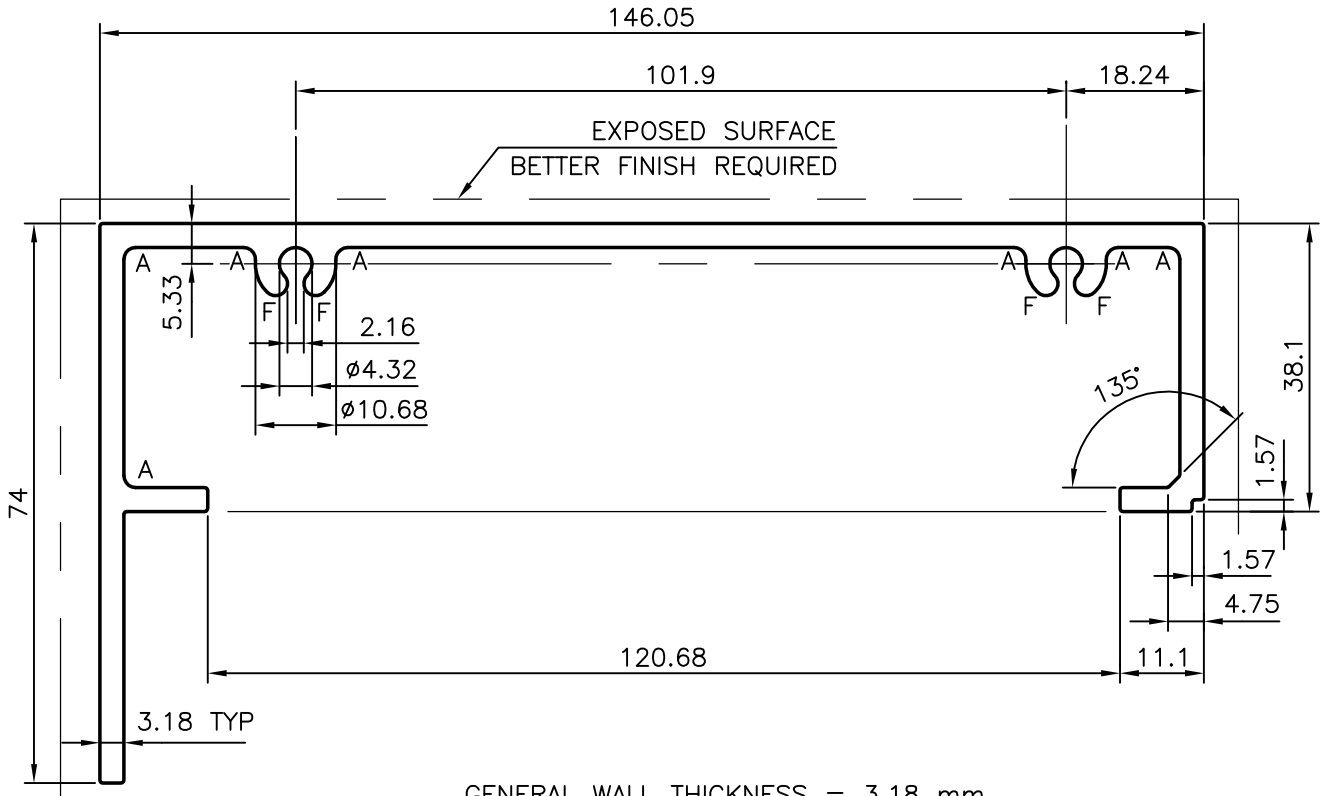

GENERAL WALL THICKNESS = 3.18 mm

F = FULL RADIUS (4 PLACES)

A = R 1.57 (7 PLACES)



SYMBOL OF QUALITY
AN ISO 9001 COMPANY

JINDAL ALUMINIUM LTD.
BANGALORE-560073 (INDIA)

	NAME	DATE
DRAWN	MALINGAPPA	23-06-2005
CHECKED		
APPROVED		
SCALE		1:1
AREA mm ²		947.454
PERIMETER mm.		584.475
WEIGHT kg/m		2.558
DRAWING No.	SECTION No.	
P-5603	-	
22896	22896	

1. ALL DIMENSIONS ARE IN mm.
2. ROUND OFF ALL SHARP CORNERS WITH 0.40 mm.
3. TOLERANCES WILL BE AS PER COMMERCIAL UNLESS OTHERWISE SPECIFIED

PARTY'S NAME	PROSOURCE SOLUTIONS INC., CANADA
PARTY'S DRAWING No.	WS-4235
ALLOY & TEMPER	6060 T5
DESCRIPTION	ARCHITECTURAL MISCELLANEOUS SECTION