

P-10012

22909

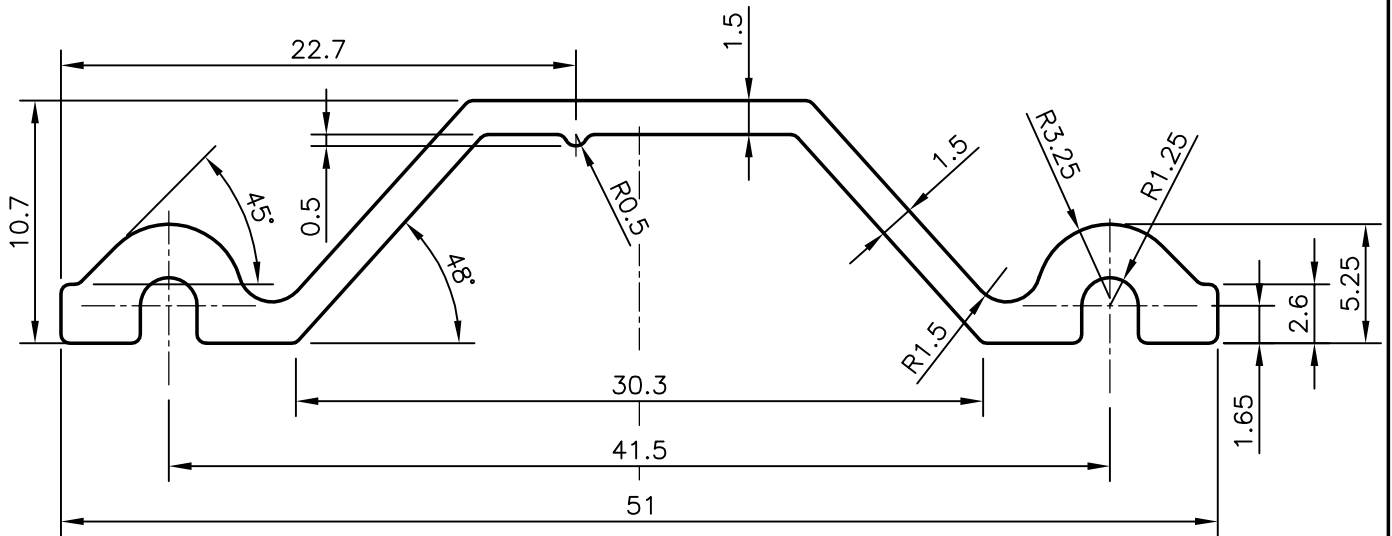
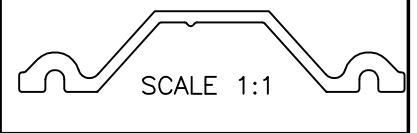

JINDAL ALUMINIUM LTD.
BANGALORE-560073 (INDIA)

	NAME	DATE
DRAWN	J.P.KAUSHIK	07-05-2010
CHECKED		
APPROVED	S.S.GARG	14-06-2010

1. ALL DIMENSIONS ARE IN mm.
2. ROUND OFF ALL SHARP CORNERS WITH 0.40 mm.
3. TOLERANCES WILL BE AS PER IS:3965-1981 UNLESS OTHERWISE SPECIFIED

SCALE	3:1
AREA mm ²	120.81
PERIMETER mm.	137.171
WEIGHT kg/m	0.326

PARTY'S NAME	GENERAL CATEGORY BANGALORE MARKET
PARTY'S DRAWING No.	AS PER SAMPLE
ALLOY & TEMPER	HE9 WP
DESCRIPTION	ARCHITECTURAL SECTION

DRAWING No.	SECTION No.
P-10012	-
22909	22909