

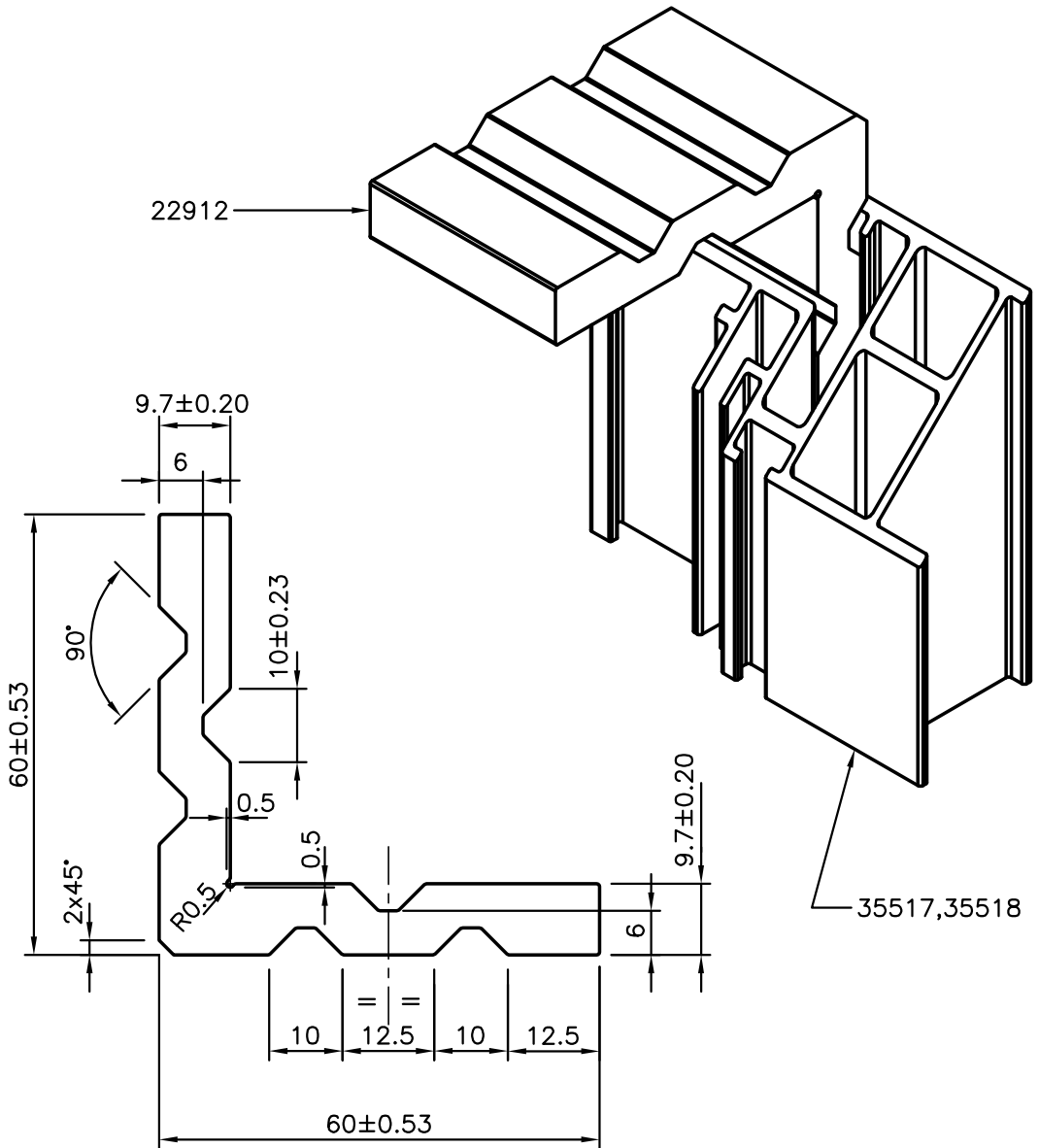

P-9129-2

S2102

22912



TWIST = 1.7/M
 STRAIGHTNESS = 1.7/M
 ANGULARITY = ±1.5°
 FLATNESS = ± 0.60

 SYMBOL OF QUALITY AN ISO 9001 COMPANY	JINDAL ALUMINIUM LTD. BANGALORE-560073 (INDIA)	NAME		DATE
		DRAWN	J.P.KAUSHIK	30-03-2009
1. ALL DIMENSIONS ARE IN mm. 2. ROUND OFF ALL SHARP CORNERS WITH 0.40 mm. 3. TOLERANCES WILL BE AS PER IS:3965-1981 UNLESS OTHERWISE SPECIFIED		CHECKED		
		APPROVED		
PARTY'S NAME LIKPROOF INDIA PVT. LTD., MUMBAI		SCALE		1:1
		AREA mm ²		927.294
PARTY'S DRAWING No. 9641		PERIMETER mm.		257.29
		WEIGHT kg/m		2.504
ALLOY & TEMPER HE9 WP		DRAWING No.		P-9129-2
		SECTION No.		-
DESCRIPTION MISC.SECTION		S2102		S2102
		22912		22912