

P-10394
S2764
22913

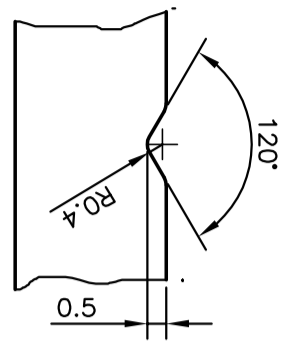

DETAIL 'A'
SCALE 5:1

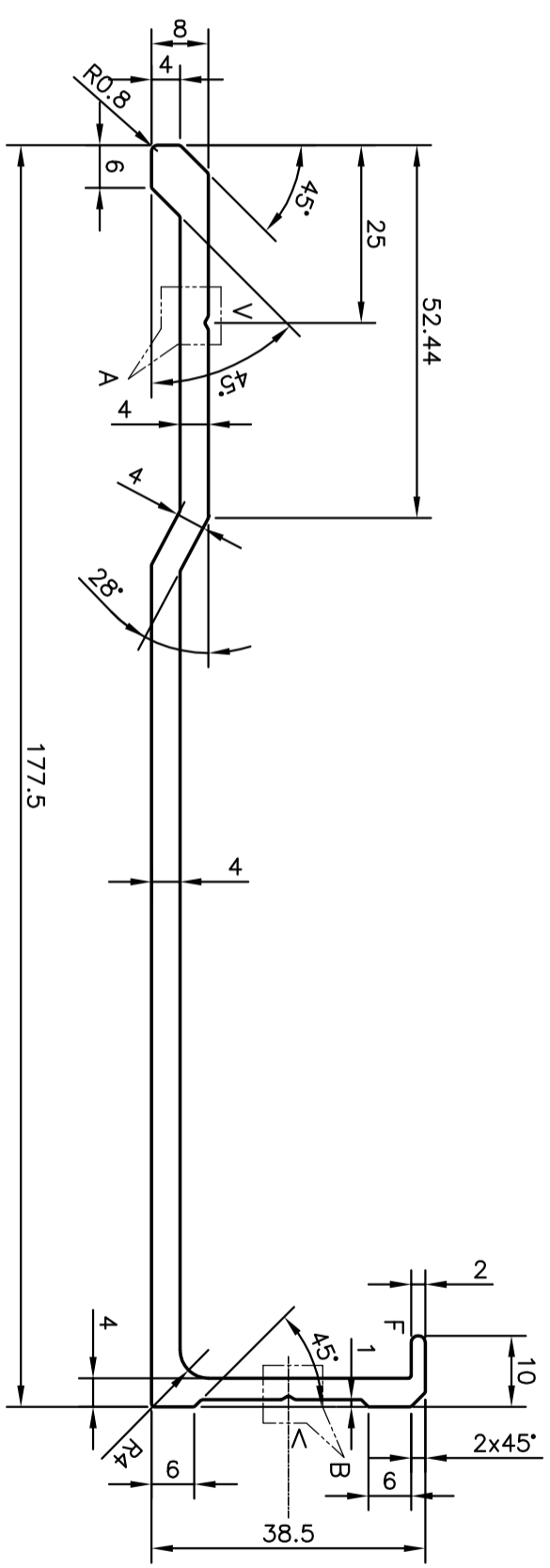
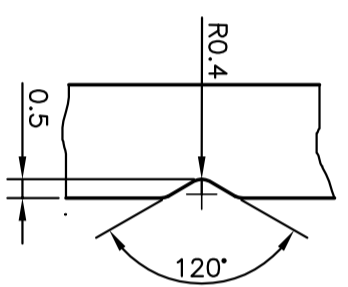

DETAIL 'B'
SCALE 5:1

F = FULL RADIUS

 SYMBOL OF QUALITY AN ISO 9001 COMPANY		JINDAL ALUMINIUM LTD. BANGALORE-560073 (INDIA)	
1. ALL DIMENSIONS ARE IN mm. 2. ROUND OFF ALL SHARP CORNERS WITH 0.40 mm. 3. TOLERANCES WILL BE AS PER IS:3965-1981 UNLESS OTHERWISE SPECIFIED		DRAWN J.P.KAUSHIK 18-09-2010	DATE 18-09-2010
PARTY'S NAME	MASCON CONSTRUCTION SYSTEM PVT. LTD., MUMBAI	CHECKED	
PARTY'S DRAWING No.	BHX225	APPROVED	S.S.GARG 18-11-2010
ALLOY & TEMPER	6061 T6	SCALE	1:1
DESCRIPTION/END USE	BULKHEAD-225 mm SECTION	AREA mm ²	864.262
		PERIMETER mm.	446.046
		WEIGHT kg/m	2.334
		DRAWING No.	SECTION No.
		P-10394	-
		S2764	S2764
		22913	22913