

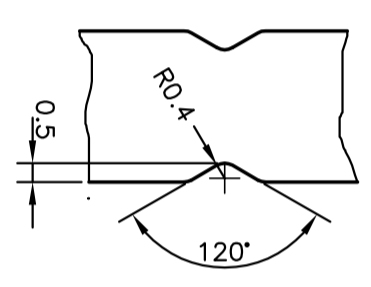

P-9537-1
S2328
22919

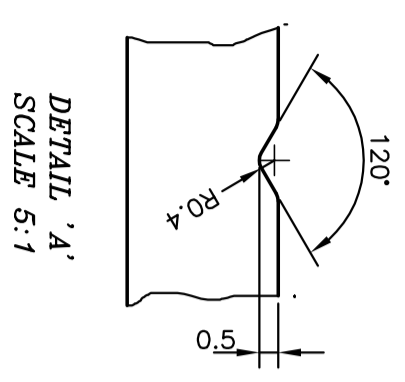
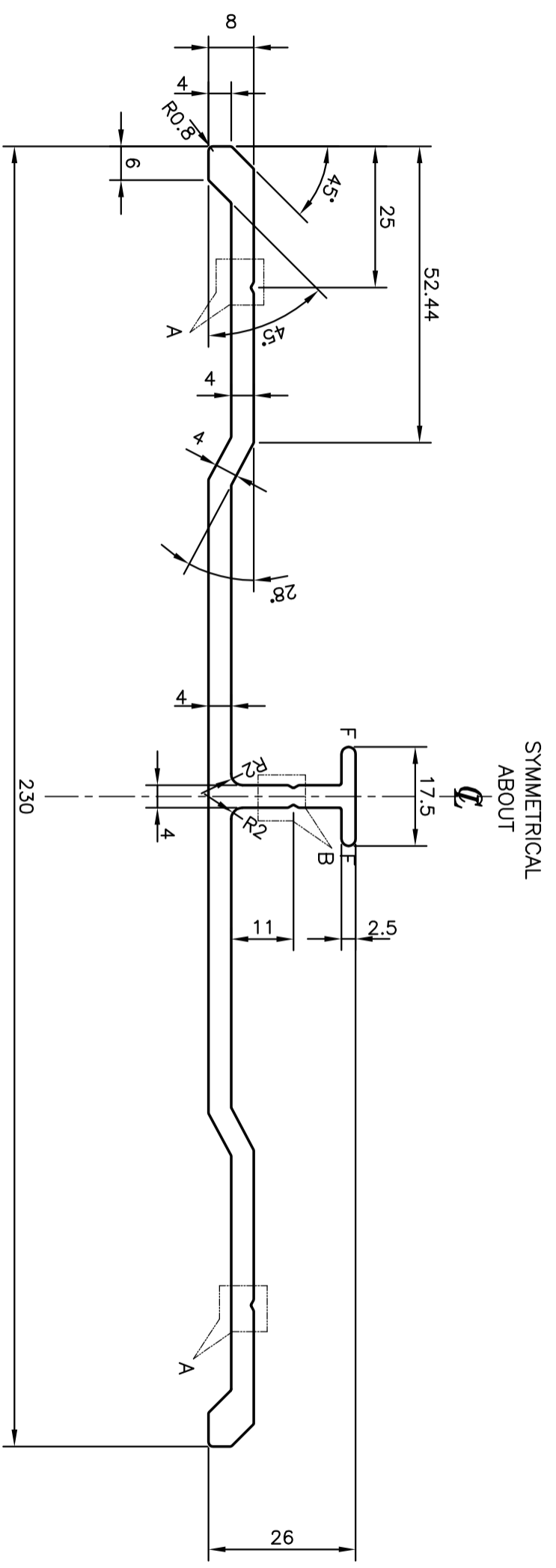

F = FULL RADIUS (2 PLACES)

 SYMBOL OF QUALITY AN ISO 9001 COMPANY		JINDAL ALUMINIUM LTD. BANGALORE-560073 (INDIA)	
1. ALL DIMENSIONS ARE IN mm. 2. ROUND OFF ALL SHARP CORNERS WITH 0.40 mm. 3. TOLERANCES WILL BE AS PER IS:3965-1981 UNLESS OTHERWISE SPECIFIED		DRAWN J.P. KAUSHIK 23-10-2009	NAME DATE
PARTY'S NAME MASCON CONSTRUCTION SYSTEM PVT. LTD., MUMBAI	PARTY'S DRAWING No. BHX100	CHECKED 	APPROVED
ALLOY & TEMPER 6061 T6	DESCRIPTION BULKHEAD-100 mm SECTION	SCALE 1:1	AREA mm ² 1098.362
		PERIMETER mm. 546.813	WEIGHT kg/m 2.966
		DRAWING No. P-9537-1	SECTION No. -
		S2328 22919	S2328 22919