

P-8843

S2702

22920

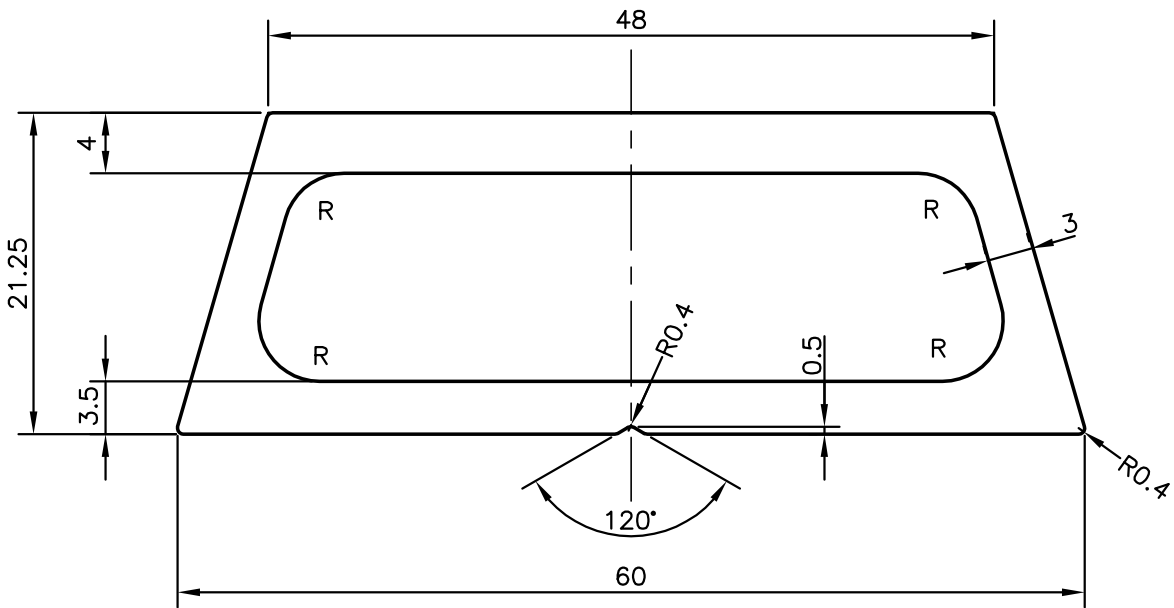
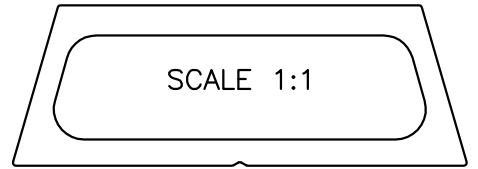

NOTE:-

R = RADIUS 4.0 mm (4 PLACES)



SYMBOL OF QUALITY
AN ISO 9001 COMPANY

JINDAL ALUMINIUM LTD.
BANGALORE-560073 (INDIA)

	NAME	DATE
DRAWN	ABHARANI	26-11-2008
CHECKED		
APPROVED	S.S.GARG	29-09-2010
SCALE		2:1
AREA mm ²		507.117
PERIMETER mm.		151.928
WEIGHT kg/m		1.369
DRAWING No.	SECTION No.	
P-8843	-	
S2702	S2702	
22920	22920	

1. ALL DIMENSIONS ARE IN mm.
2. ROUND OFF ALL SHARP CORNERS WITH 0.4 mm.
3. TOLERANCES WILL BE AS PER IS:6477-1983 UNLESS OTHERWISE SPECIFIED

PARTY'S NAME	MASCON CONSTRUCTION SYSTEM PVT. LTD., MUMBAI
PARTY'S DRAWING No.	WRX
ALLOY & TEMPER	6061 T6
DESCRIPTION	WALL PANEL RIB SECTION