

P-8845-1

S2703

22926

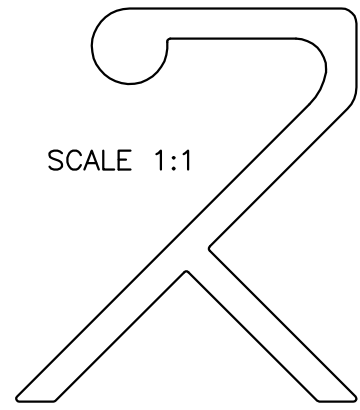

SCALE 1:1

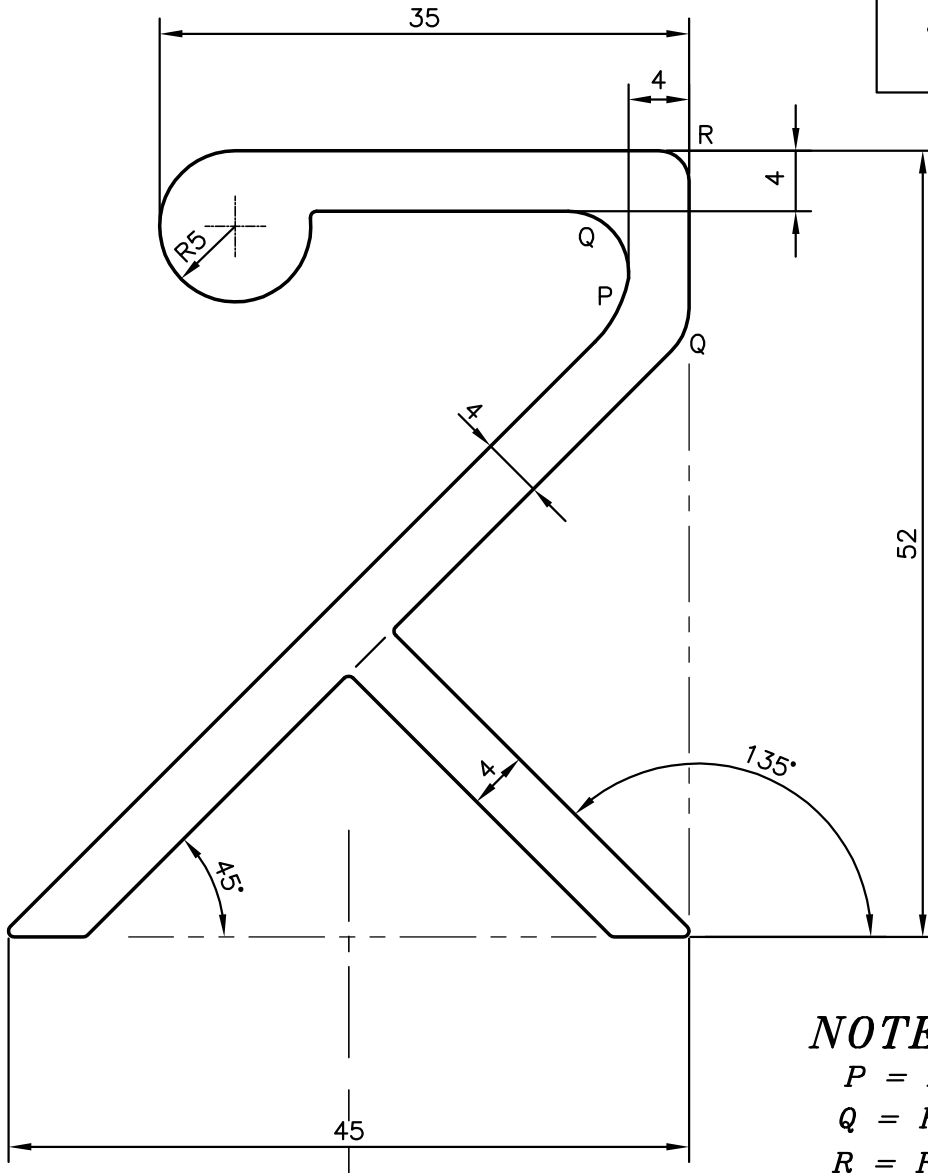

**NOTE:-**

- P = RADIUS 8.0 mm(1PLACE)
- Q = RADIUS 4.0 mm(2PLACES)
- R = RADIUS 2.0 mm(1PLACE)



SYMBOL OF QUALITY  
AN ISO 9001 COMPANY

**JINDAL ALUMINIUM LTD.**  
BANGALORE-560073 (INDIA)

	NAME	DATE
DRAWN	J.P.KAUSHIK	18-09-2010
CHECKED		
APPROVED	S.S.GARG	29-09-2010
SCALE		2:1
AREA mm <sup>2</sup>		552.855
PERIMETER mm.		264.325
WEIGHT kg/m		1.493
DRAWING No.	SECTION No.	
P-8845-1	-	
S2703	S2703	
22926	22926	

1. ALL DIMENSIONS ARE IN mm.
2. ROUND OFF ALL SHARP CORNERS WITH 0.4 mm.
3. TOLERANCES WILL BE AS PER IS:3965-1981 UNLESS OTHERWISE SPECIFIED

PARTY'S NAME	MASCON CONSTRUCTION SYSTEM PVT. LTD., MUMBAI
PARTY'S DRAWING No.	HRX
ALLOY & TEMPER	6061 T6
DESCRIPTION	HANDRAIL SECTION