

P-12582
S3695
22936

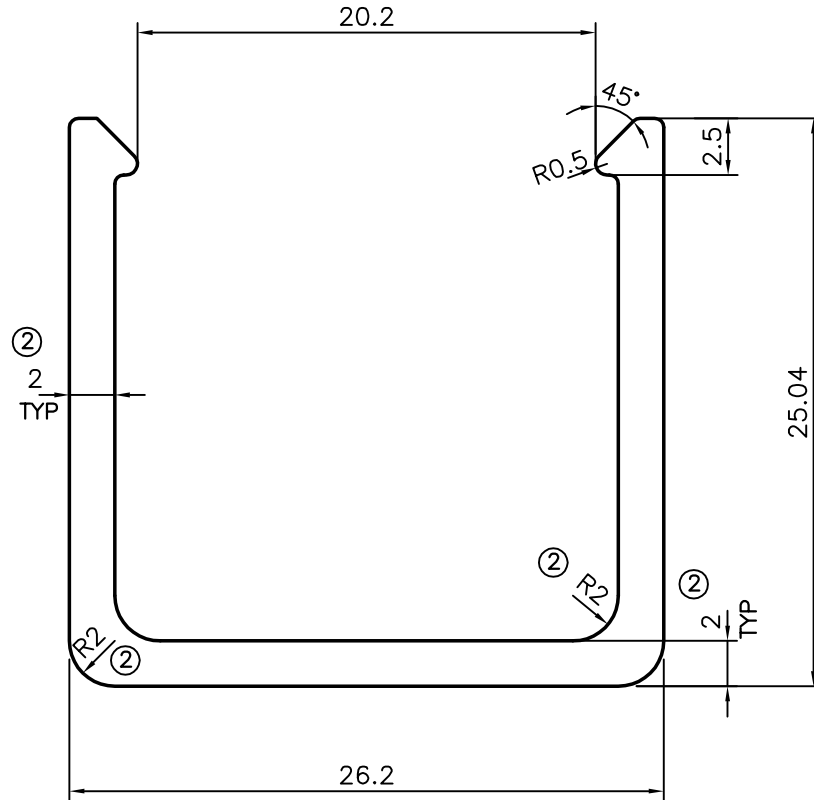
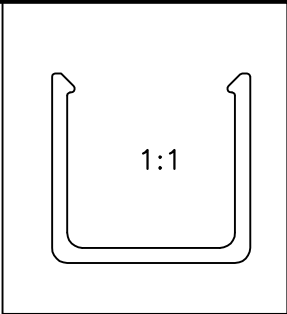
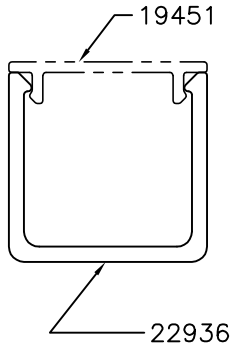

NOTE: -

PLEASE CHECK FITTING WITH MATCHING PART, IF REQUIRED DO MANUAL CORRECTION

ISSUE-2

DIMENSION CHANGED FROM 21.4 TO 20.2 WALL THICKNESS CHANGED FROM 1.4 TO 2.0 mm
RADIUS CHANGED FROM 1.4 TO 2.0 mm

 SYMBOL OF QUALITY AN ISO 9001 COMPANY	JINDAL ALUMINIUM LTD. BANGALORE-560073 (INDIA)	NAME	DATE
		DRAWN	J.P.KAUSHIK 21-03-2013
		CHECKED	
		APPROVED	S.S.GARG 25-03-2013
		SCALE	3:1
		AREA mm ²	146.224
		PERIMETER mm.	145.85
		WEIGHT kg/m	0.395
PARTY'S NAME	SRINATHJI ALUMINIUM ENTERPRISES, CHENNAI	DRAWING No.	SECTION No.
PARTY'S DRAWING No.	SAE-LOUVER-DIE-DRG-001	P-12582	-
ALLOY & TEMPER	HE9 WP	S3695	S3695(ISSUE-2)
		22936	22936
DESCRIPTION	MISC. CHANNEL SECTION		