

P-11494-1

S3243

22941

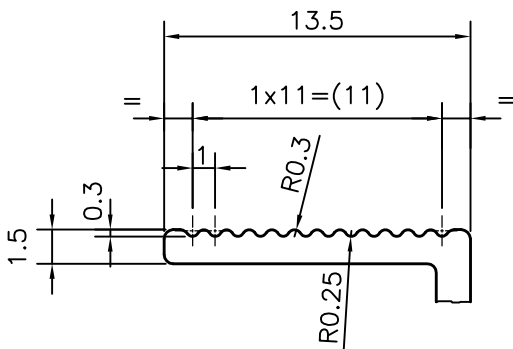
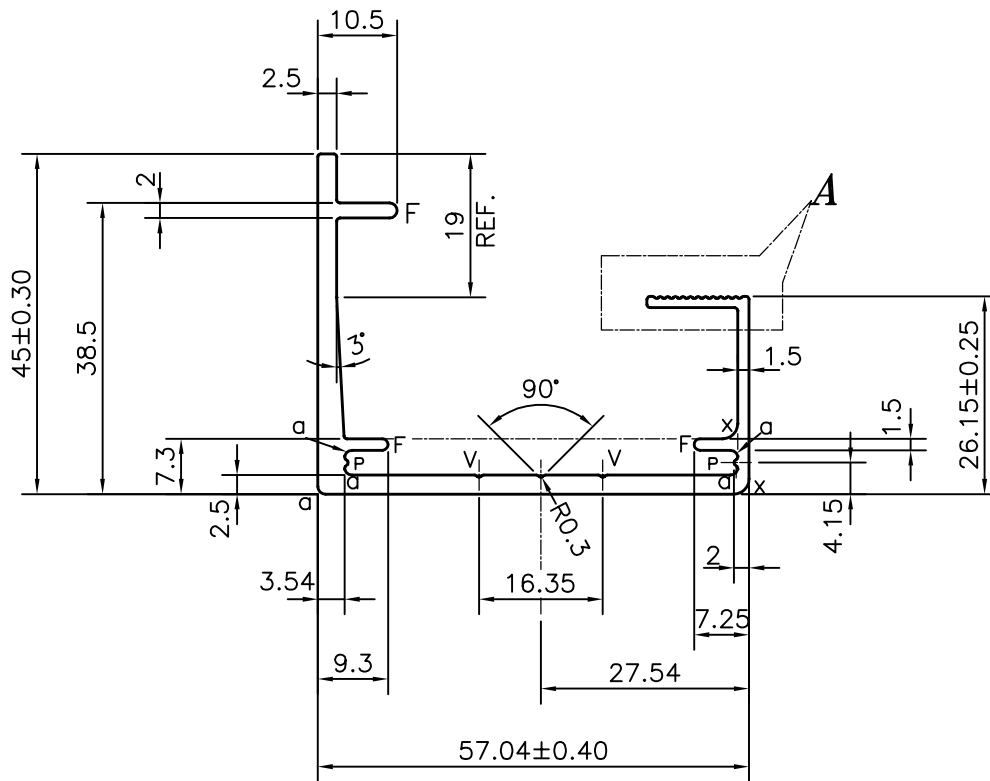

DETAIL OF "A"  
SCALE 3:1

- a = RADIUS 1 mm. (5 PLACES)
- x = RADIUS 2 mm. (2 PLACES)
- V = VEE GROOVE 0.3x90° (3 PLACES)
- P = PIP 0.5x90° (2 PLACES)
- F = FULL RADIUS (3 PLACES)

 SYMBOL OF QUALITY AN ISO 9001 COMPANY	<b>JINDAL ALUMINIUM LTD.</b> BANGALORE-560073 (INDIA)	NAME	DATE
		DRAWN	PARVESH
		CHECKED	
		APPROVED	S.S.GARG
		SCALE	1:1
		AREA mm <sup>2</sup>	347.894
		PERIMETER mm.	309.873
		WEIGHT kg/m	0.939
PARTY'S NAME	SPACEBIZ SOLUTIONS PVT. LTD., BANGALORE	DRAWING No.	SECTION No.
PARTY'S DRAWING No.	AS PER DRAWING	P-11494-1	-
ALLOY & TEMPER	HE9 WP	S3243	S3243
		22941	22941
DESCRIPTION	CURTAIN WALL SECTION		