

P-11537-2

S3246

22944

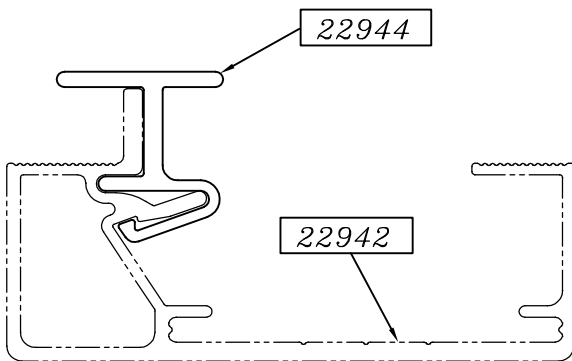
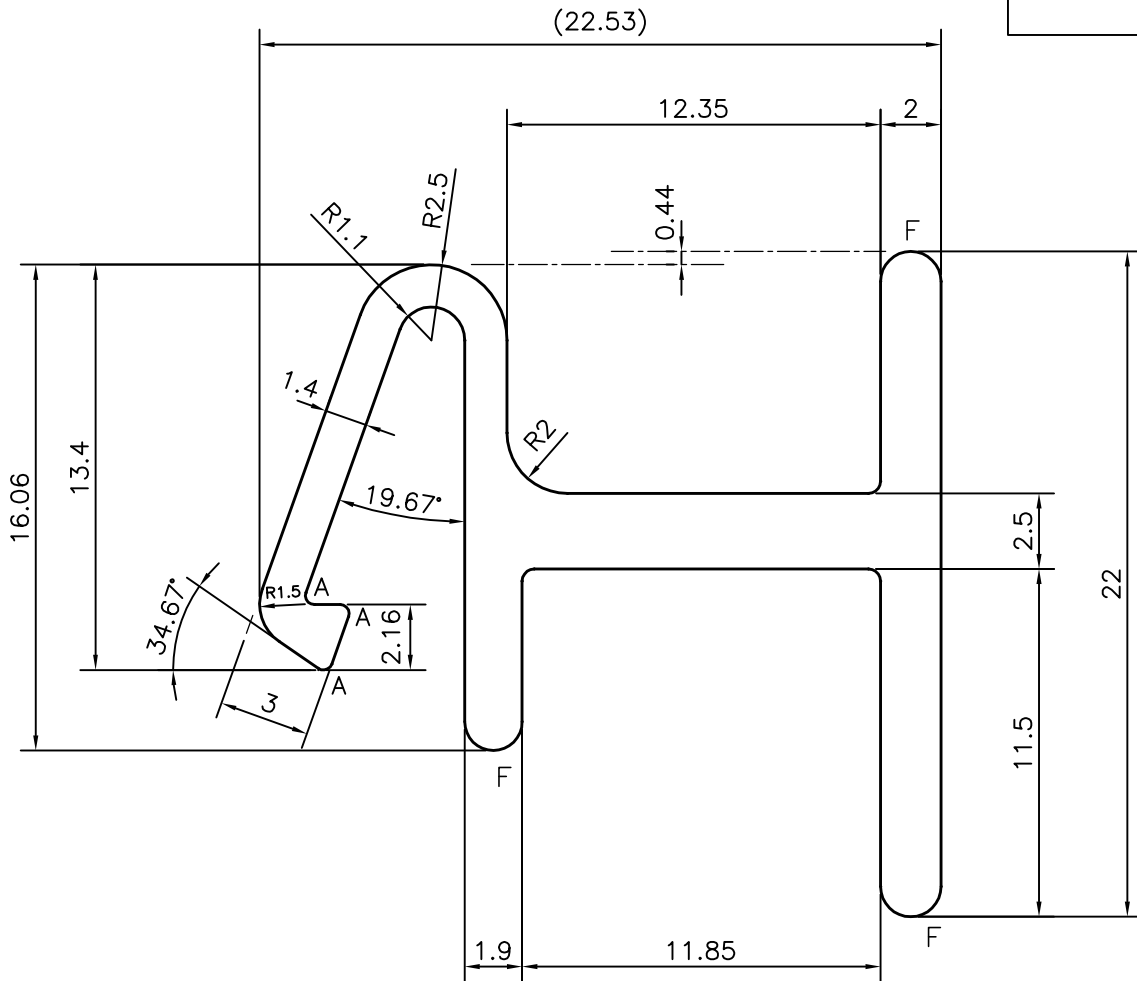
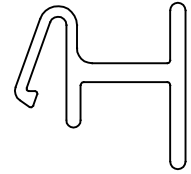

A = RADIUS 0.3 mm. (3 PLACES)
 F = FULL RADIUS (3 PLACES)



SYMBOL OF QUALITY
 AN ISO 9001 COMPANY

JINDAL ALUMINIUM LTD.
 BANGALORE-560073 (INDIA)

	NAME	DATE
DRAWN	PARVESH	21-03-2012
CHECKED		
APPROVED	S.S.GARG	02-04-2012
SCALE		4:1
AREA mm ²		121.839
PERIMETER mm.		128.988
WEIGHT kg/m		0.329
DRAWING No.	SECTION No.	
P-11537-2	-	
S3246	S3246	
22944	22944	

1. ALL DIMENSIONS ARE IN mm.
2. ROUND OFF ALL SHARP CORNERS WITH 0.40 mm.
3. TOLERANCES WILL BE AS PER DIN:EN-12020-2 ,UNLESS OTHERWISE SPECIFIED

PARTY'S NAME	SPACEBIZ SOLUTIONS PVT. LTD., BANGALORE
PARTY'S DRAWING No.	AS PER DRAWING
ALLOY & TEMPER	HE9 WP
DESCRIPTION	CURTAIN WALL SECTION