

P-11804

S3388

22946

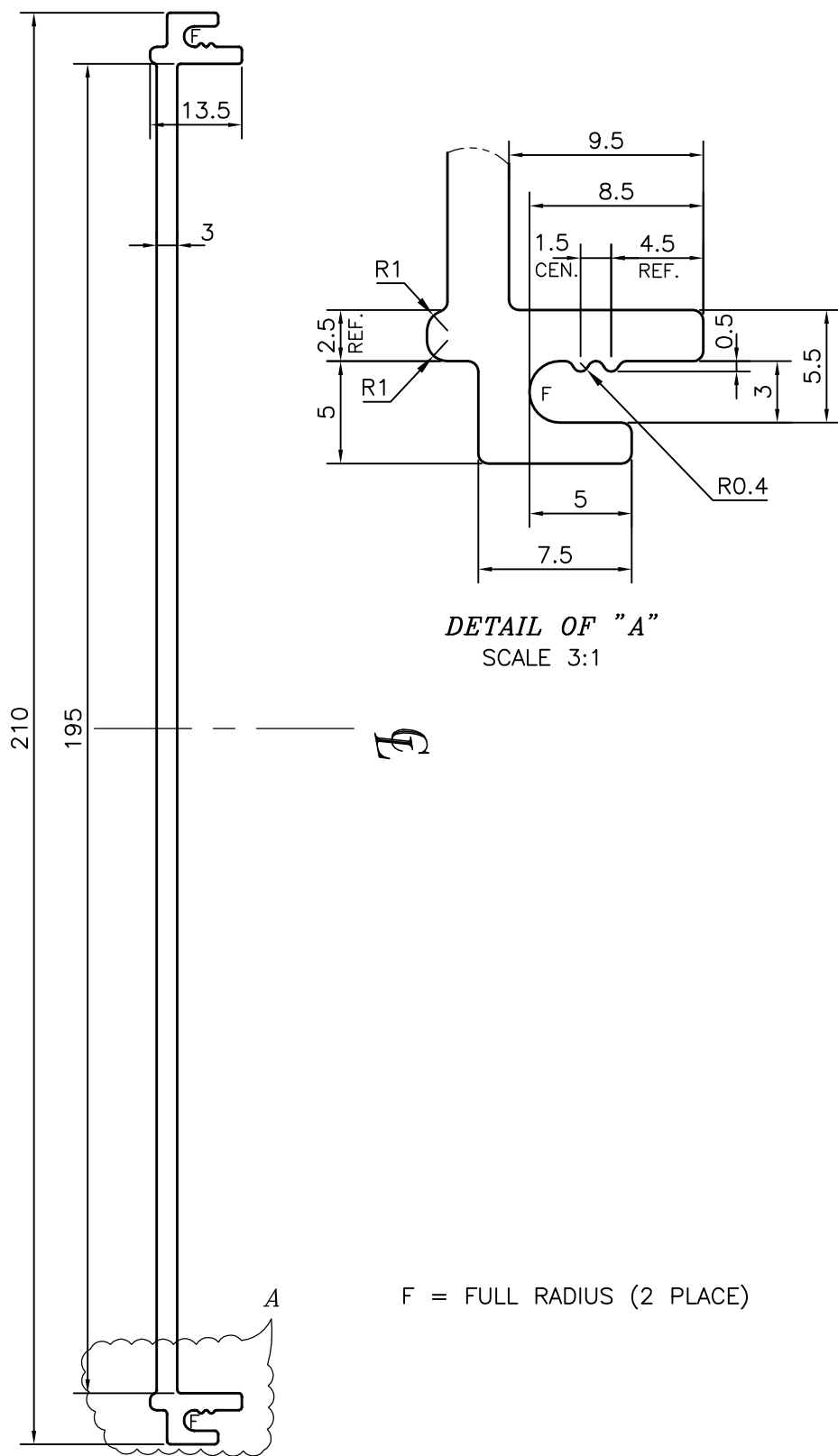

DETAIL OF "A"
SCALE 3:1

F = FULL RADIUS (2 PLACE)



SYMBOL OF QUALITY
AN ISO 9001 COMPANY

JINDAL ALUMINIUM LTD.
BANGALORE-560073 (INDIA)

	NAME	DATE
DRAWN	PARVESH	08-06-2012
CHECKED		
APPROVED	S.S.GARG	10-07-2012
SCALE		1:1
AREA mm ²		699.794
PERIMETER mm.		482.086
WEIGHT kg/m		1.889
DRAWING No.	SECTION No.	
P-11804	-	
S3388	S3388	
22946	22946	

1. ALL DIMENSIONS ARE IN mm.
2. ROUND OFF ALL SHARP CORNERS WITH 0.50 mm.
3. TOLERANCES WILL BE AS PER IS:3965-1981, UNLESS OTHERWISE SPECIFIED

PARTY'S NAME	TRISTAR GLOBAL INFRASTRUCTURE (P) LTD., NEW DELHI
PARTY'S DRAWING No.	VEX 484 ISSUE A
ALLOY & TEMPER	6063 T6
DESCRIPTION	EXPENSION JOINTS SECTION