

P-12251

S3564

22956

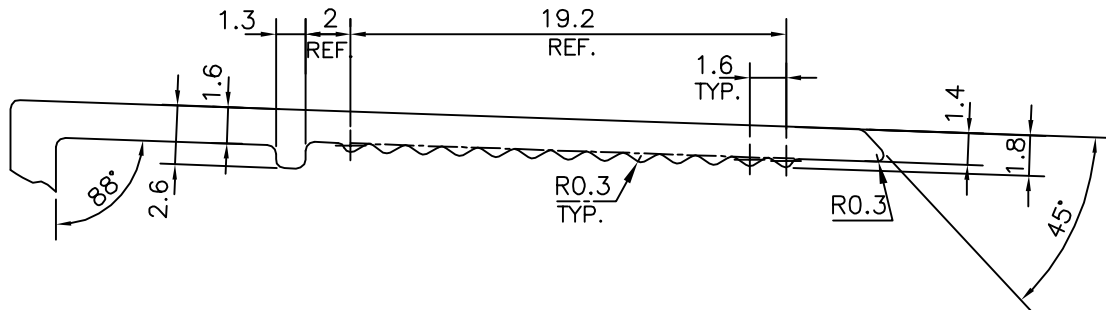
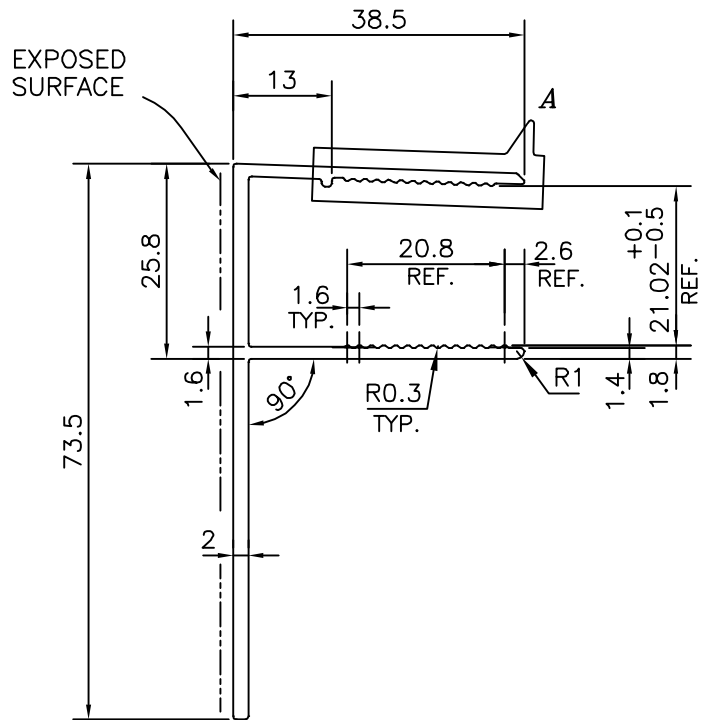

DETAIL OF "A"
SCALE 3:1



SYMBOL OF QUALITY
AN ISO 9001 COMPANY

JINDAL ALUMINIUM LTD.
BANGALORE-560073 (INDIA)

	NAME	DATE
DRAWN	PARVESH	19-11-2012
CHECKED		
APPROVED	S.S.GARG	22-11-2012
SCALE		1:1
AREA mm ²		263.015
PERIMETER mm.		301.647
WEIGHT kg/m		0.710
DRAWING No.	SECTION No.	
P-12251	-	
S3564	S3564	
22956	22956	

1. ALL DIMENSIONS ARE IN mm.
2. ROUND OFF ALL SHARP CORNERS WITH 0.40 mm.
3. TOLERANCES WILL BE AS PER IS:3965-1981 , UNLESS OTHERWISE SPECIFIED

PARTY'S NAME	DAN PAL (INDIA) PVT. LTD.,DELHI
PARTY'S DRAWING No.	DPI/FPD-22/01/R-0
ALLOY & TEMPER	6063 T5
DESCRIPTION	ALUMINIUM FPD-22mm