

P-14571-1

22965

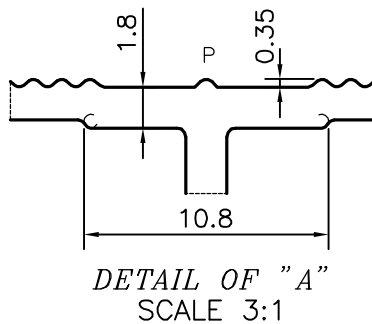

P = PIP 0.35x90° (1 PLACE)

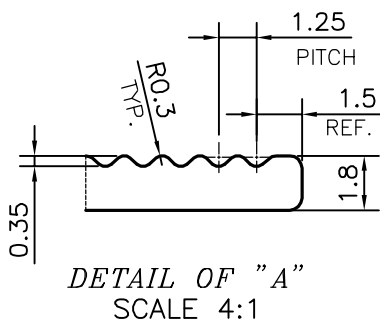
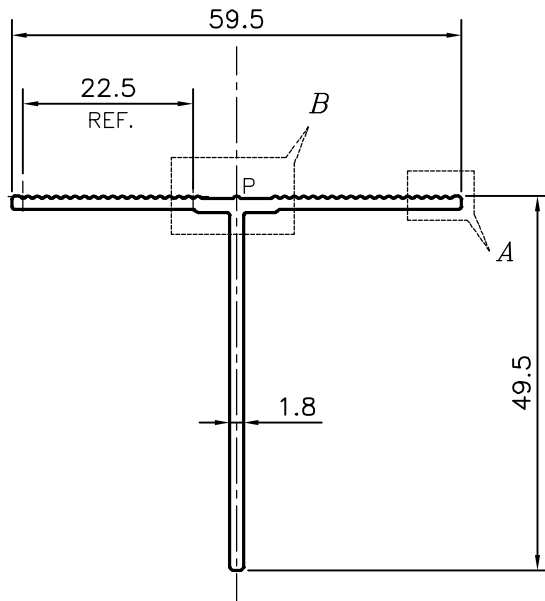

SYMBOL OF QUALITY
AN ISO 9001 COMPANY

JINDAL ALUMINIUM LTD.
BANGALORE-560073 (INDIA)

	NAME	DATE
DRAWN	PARVESH	21-04-2015
CHECKED		
APPROVED	S.S.GARG	27-04-2015
SCALE		1:1
AREA mm ²		184.489
PERIMETER mm.		225.197
WEIGHT kg/m		0.498
DRAWING No.	SECTION No.	
P-14571-1	-	
22965	22965	

1. ALL DIMENSIONS ARE IN mm.
2. ROUND OFF ALL SHARP CORNERS WITH 0.40 mm.
3. TOLERANCES WILL BE AS PER BS:EN-755-9 , UNLESS OTHERWISE SPECIFIED

PARTY'S NAME	UAB LEMORA, LITHUANIA
PARTY'S DRAWING No.	AS PER DRAWING
ALLOY & TEMPER	6063 T6
DESCRIPTION	FLUTED TEE SECTION