

P-14572

22966

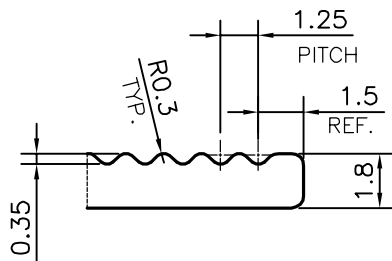

DETAIL OF "A"  
SCALE 4:1

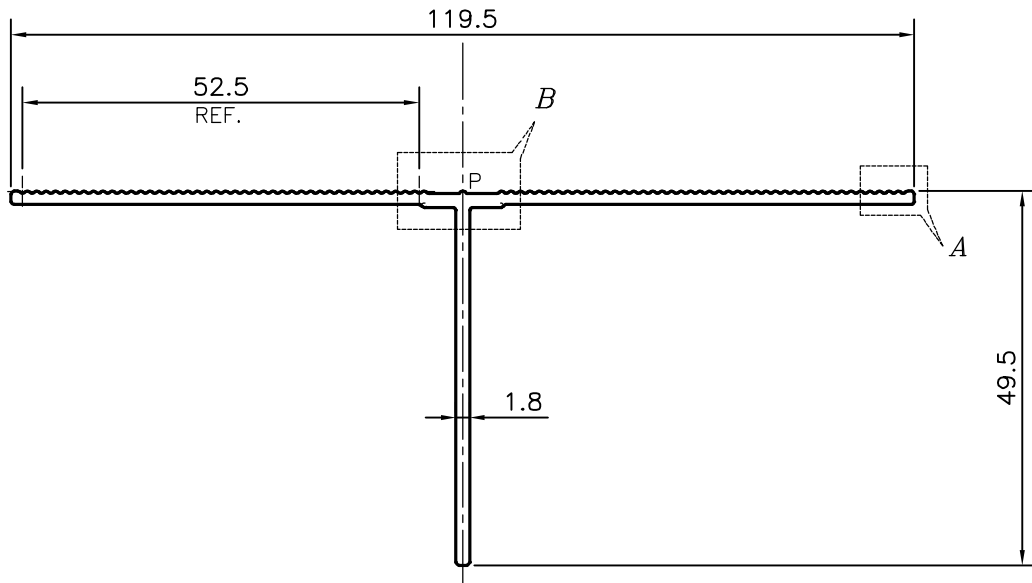
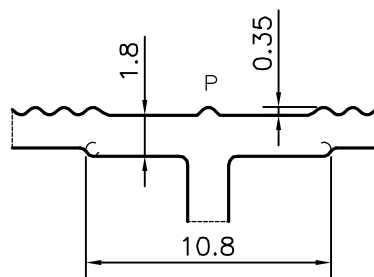

DETAIL OF "A"  
SCALE 3:1

P = PIP 0.35x90° (1 PLACE)



SYMBOL OF QUALITY  
AN ISO 9001 COMPANY

**JINDAL ALUMINIUM LTD.**  
BANGALORE-560073 (INDIA)

	NAME	DATE
DRAWN	PARVESH	25-04-2015
CHECKED		
APPROVED	S.S.GARG	27-04-2015
SCALE		1:1
AREA mm <sup>2</sup>		281.991
PERIMETER mm.		355.945
WEIGHT kg/m		0.761
DRAWING No.	SECTION No.	
P-14572	-	
22966	22966	

1. ALL DIMENSIONS ARE IN mm.
2. ROUND OFF ALL SHARP CORNERS WITH 0.40 mm.
3. TOLERANCES WILL BE AS PER BS:EN-755-9 , UNLESS OTHERWISE SPECIFIED

PARTY'S NAME	UAB LEMORA, LITHUANIA
PARTY'S DRAWING No.	AS PER DRAWING
ALLOY & TEMPER	6063 T6
DESCRIPTION	FLUTED TEE SECTION