

P-15282

22977

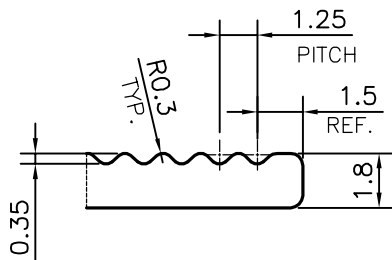

DETAIL OF "A"
SCALE 4:1

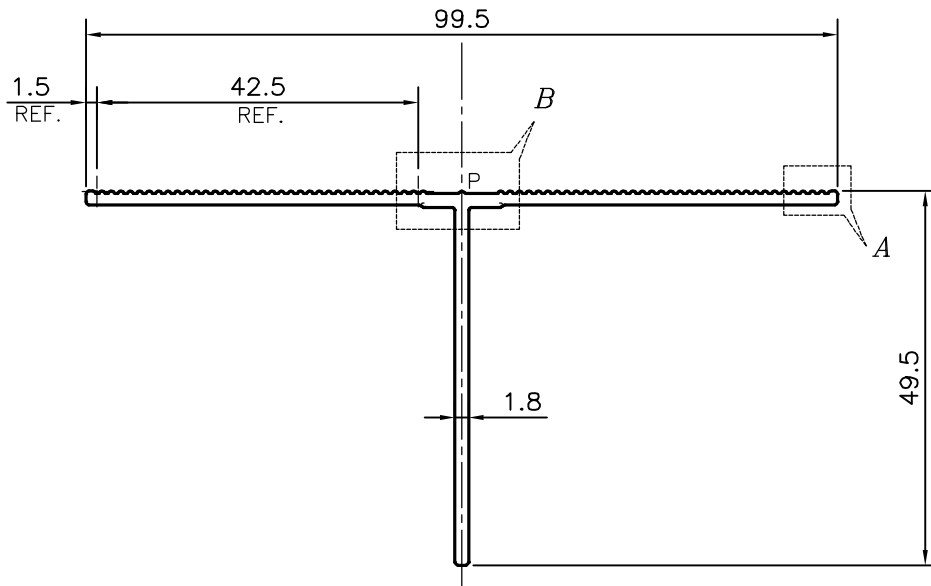
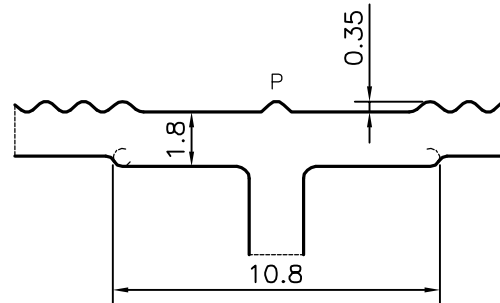

DETAIL OF "B"
SCALE 4:1

P = PIP 0.35x90° (1 PLACE)



SYMBOL OF QUALITY
AN ISO 9001 COMPANY

JINDAL ALUMINIUM LTD.
BANGALORE-560073 (INDIA)

	NAME	DATE
DRAWN	PARVESH	03-11-2015
CHECKED		
APPROVED	S.S.GARG	06-11-2015
SCALE		1:1
AREA mm ²		249.489
PERIMETER mm.		312.367
WEIGHT kg/m		0.674
DRAWING No.	SECTION No.	
P-15282	-	
22977	22977	

1. ALL DIMENSIONS ARE IN mm.
2. ROUND OFF ALL SHARP CORNERS WITH 0.40 mm.
3. TOLERANCES WILL BE AS PER BS:EN-755-9 , UNLESS OTHERWISE SPECIFIED

PARTY'S NAME	UAB LEMORA, LITHUANIA
PARTY'S DRAWING No.	MODIFIED OF SECTION No. 22966
ALLOY & TEMPER	6063 T6
DESCRIPTION	FLUTED TEE SECTION