

P-5662

23009



1:1

WEIGHT PER 3658 mm. LONG PIECE:-0.210 kgs (AVERAGE)

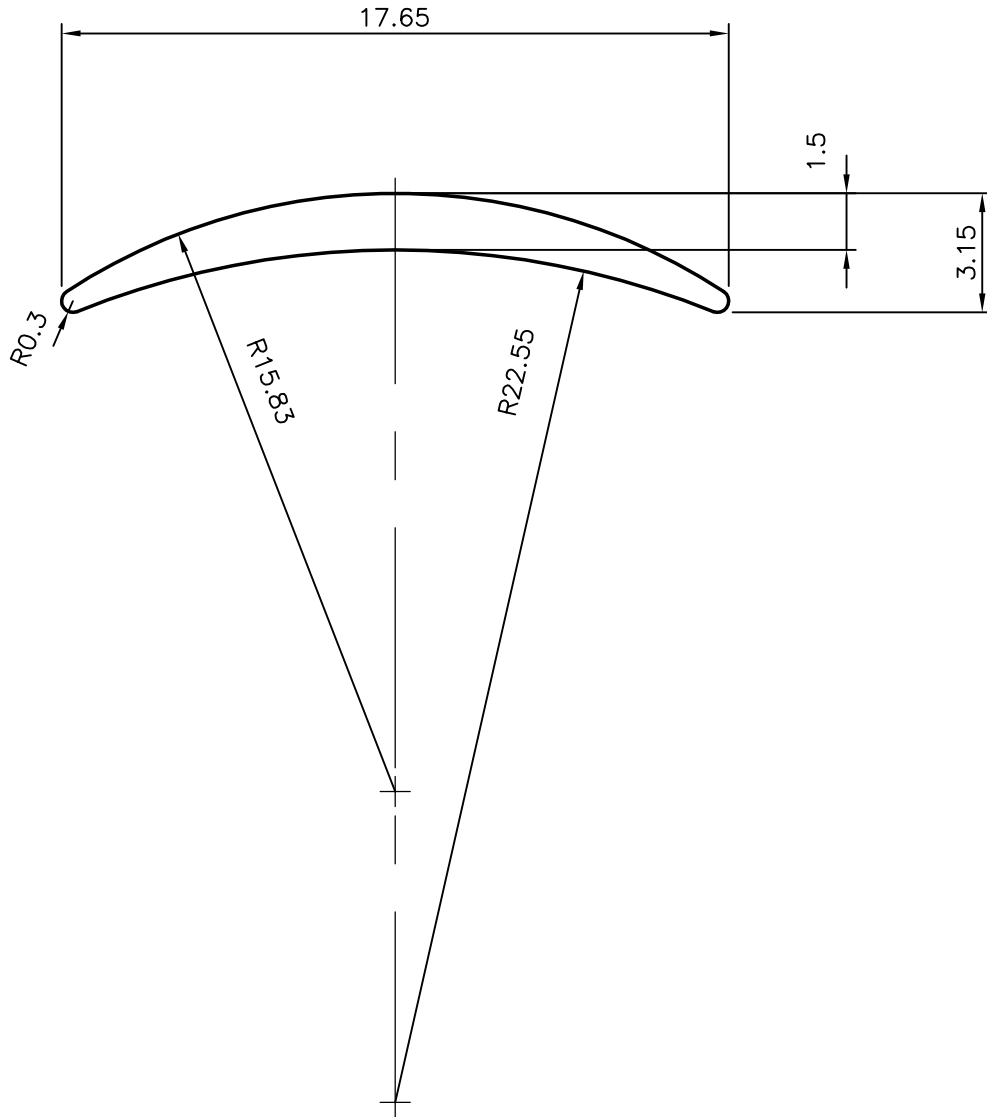

SYMBOL OF QUALITY
AN ISO 9002 COMPANY

JINDAL ALUMINIUM LTD.
BANGALORE-560073 (INDIA)

	NAME	DATE
DRAWN	MALINGAPPA	09-07-2005
CHECKED		
APPROVED		

1. ALL DIMENSIONS ARE IN mm.
2. ROUND OFF ALL SHARP CORNERS WITH 0.40 mm.
3. TOLERANCES WILL BE AS PER IS:3965-1981 UNLESS OTHERWISE SPECIFIED

SCALE	5:1
AREA mm ²	21.542
PERIMETER mm.	37.407
WEIGHT kg/m	0.058

PARTY'S NAME	GENERAL CATEGORY, KOLKATA MARKET	DRAWING No.	P-5662	SECTION No.	-
PARTY'S DRAWING No.	AS PER SAMPLE & SPECIFICATION		23009		23009
ALLOY & TEMPER	HE9 WP				
DESCRIPTION	HALF ROUND-RADIUSED				