

5138

23155

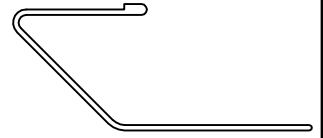

SCALE 1:1

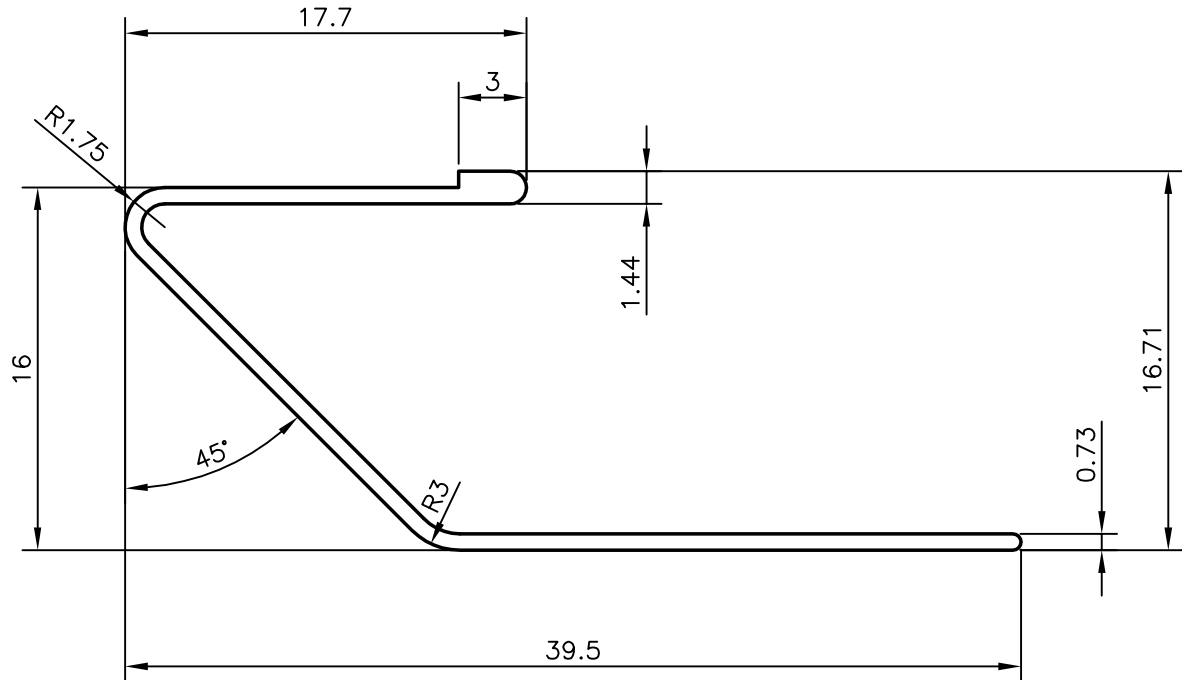

GENERAL WALL THICKNESS = 0.73 mm
 3658 mm. LONG PIECES REQD. IN 100 kgs. :- 210 (AVERAGE)



SYMBOL OF QUALITY
 AN ISO 9001 COMPANY

JINDAL ALUMINIUM LTD.
 BANGALORE-560073 (INDIA)

	NAME	DATE
DRAWN	RAGHAVENDRA	26-10-2006
CHECKED		
APPROVED		

1. ALL DIMENSIONS ARE IN mm.
2. ROUND OFF ALL SHARP CORNERS WITH 0.40 mm.
3. TOLERANCES WILL BE AS PER IS:3965-1981 UNLESS OTHERWISE SPECIFIED

SCALE	3:1
AREA mm ²	47.968
PERIMETER mm.	128.3
WEIGHT kg/m	0.130

PARTY'S NAME	-	DRAWING No.	5138	SECTION No.	5138
PARTY'S DRAWING No.	-	23155	23155		
ALLOY & TEMPER	HE9 WP				
DESCRIPTION	'J' GUTTER				