

5139

23156

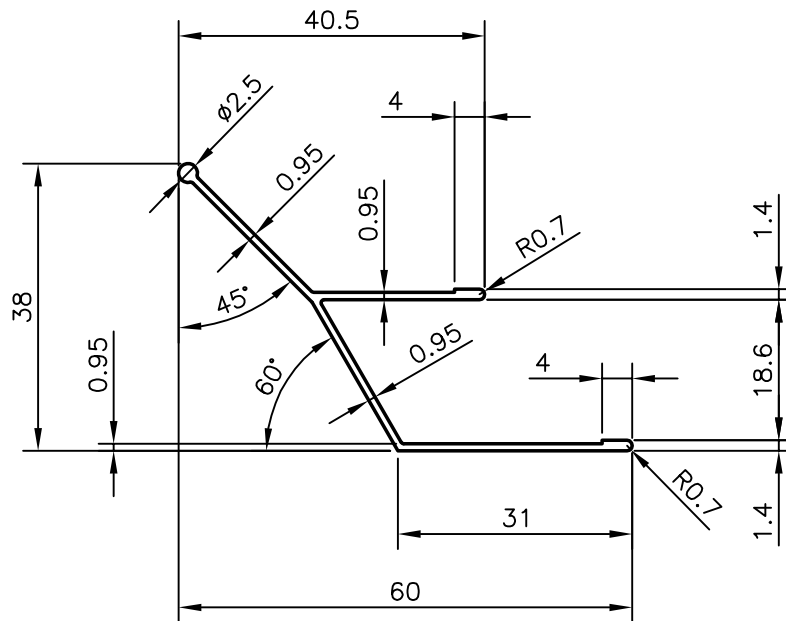

WEIGHT / 3658 mm. LONG PIECE:- 1.0 kg (AVERAGE)



SYMBOL OF QUALITY  
AN ISO 9001 COMPANY

**JINDAL ALUMINIUM LTD.**  
BANGALORE-560073 (INDIA)

	NAME	DATE
DRAWN	RAGHAVENDRA	26-10-2006
CHECKED		
APPROVED		

1. ALL DIMENSIONS ARE IN mm.
2. ROUND OFF ALL SHARP CORNERS WITH 0.40 mm.
3. TOLERANCES WILL BE AS PER IS:3965-1981 UNLESS OTHERWISE SPECIFIED

SCALE	1:1
AREA mm <sup>2</sup>	101.388
PERIMETER mm.	203.74
WEIGHT kg/m	0.273

PARTY'S NAME	-	DRAWING No.	5139	SECTION No.	5139
PARTY'S DRAWING No.	-		23156		23156
ALLOY & TEMPER	HE9 WP				
DESCRIPTION	'J' GUTTER CHANNEL				