

5143

23159

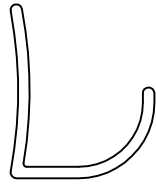

1:1

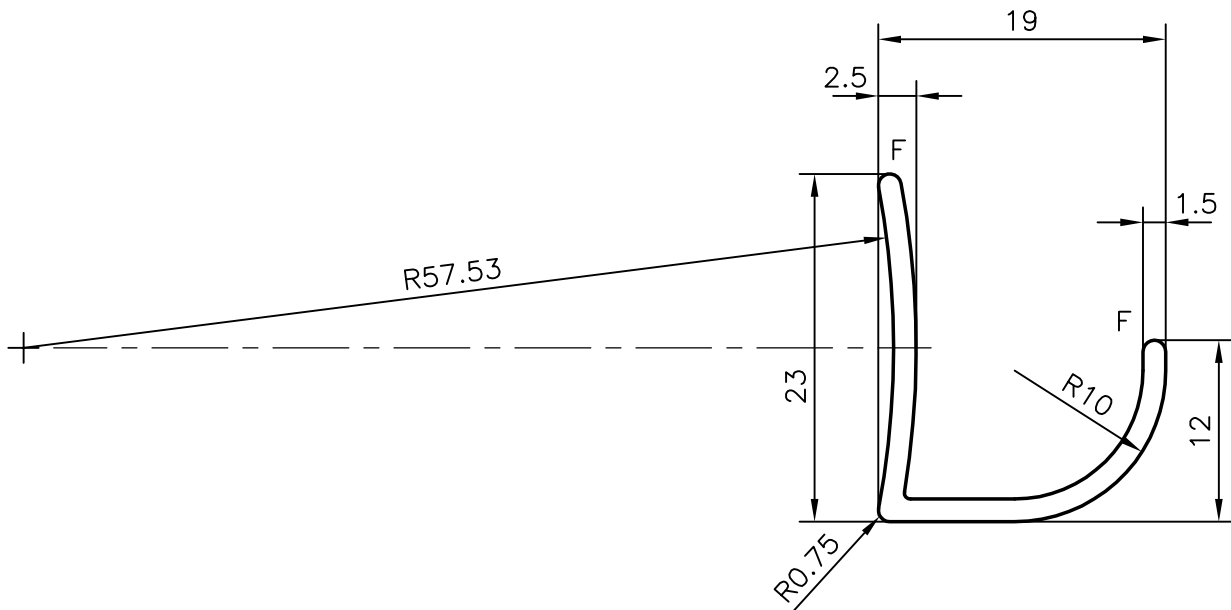

1. GENERAL WALL THICKNESS:- 1.50 mm.
2. F = FULL RADIUS (2)

JINDAL ALUMINIUM LTD.

BANGALORE-560073

		NAME	DATE
		DRAWN	R.D.Sharma
1. ALL DIMENSIONS ARE IN mm. 2. ROUND OFF ALL SHARP CORNERS WITH 0.4 mm. 3. TOLERANCES WILL BE AS PER IS: 3965-1981 ,UNLESS OTHERWISE SPECIFIED		CHECKED	
		APPROVED	
PARTY'S NAME	A.ABDUL RAHIM OOSMAN & CO.,MAURITIUS	SCALE	1:1 & 2:1
PARTY'S DRAWING No.	AS PER SAMPLE	WEIGHT kg/m	0.189
ALLOY & TEMPER	HE9 WP (6063 T6)	SECTION No.	23159
LENGTH	5500 mm.	DRAWING No.	
DESCRIPTION	WATER CHANNEL SPECIAL	23159	