

P-13156

23417

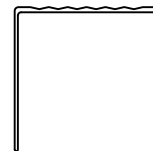

1:1

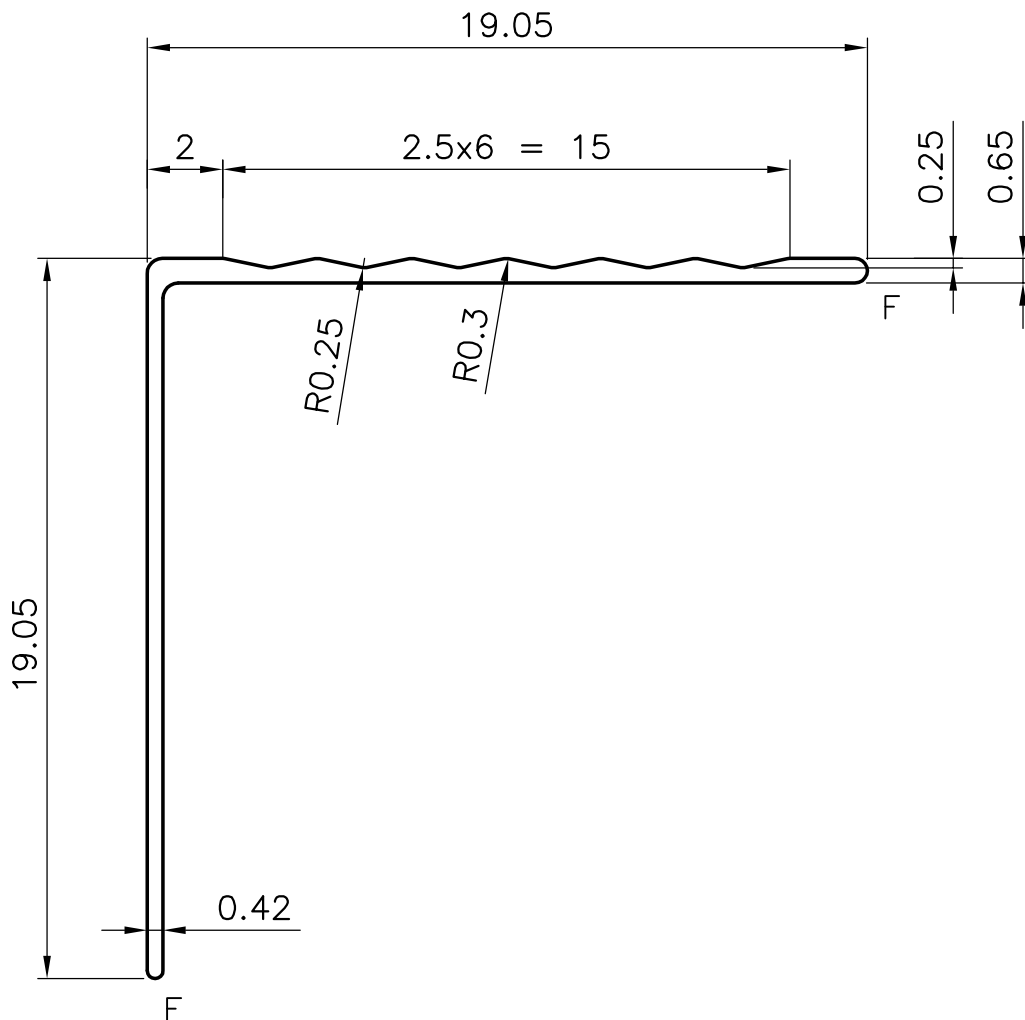

F = FULL RADIUS (2 PLACES)

3658mm LONG PIECES IN 100kgs = 558 (AVERAGE)



SYMBOL OF QUALITY
AN ISO 9001 COMPANY

JINDAL ALUMINIUM LTD.
BANGALORE-560073 (INDIA)

	NAME	DATE
DRAWN	RAGHAVENDRA	23-10-2013
CHECKED		
APPROVED	S.S.GARG	06-11-2013
SCALE		5:1
AREA mm ²		18.179
PERIMETER mm.		75.703
WEIGHT kg/m		0.049
DRAWING No.	SECTION No.	
P-13156	-	
23417	23417	

1. ALL DIMENSIONS ARE IN mm.
2. ROUND OFF ALL SHARP CORNERS WITH 0.40 mm.
3. TOLERANCES WILL BE AS PER IS:3965-1981 UNLESS OTHERWISE SPECIFIED

PARTY'S NAME	GENERAL CATEGORY, DELHI MARKET
PARTY'S DRAWING No.	LIGHTER OF SECTION NO. 23402
ALLOY & TEMPER	HE9 WP
DESCRIPTION	FLUTED ANGLE