

5107
23507

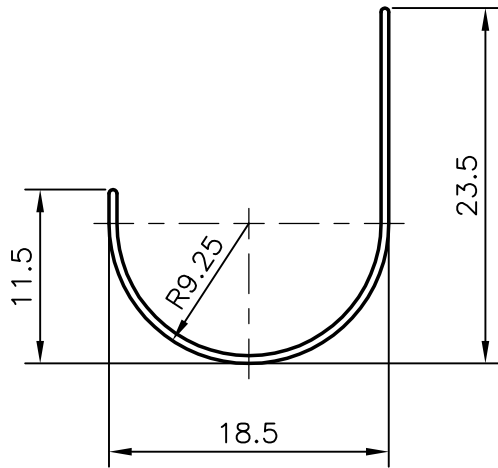
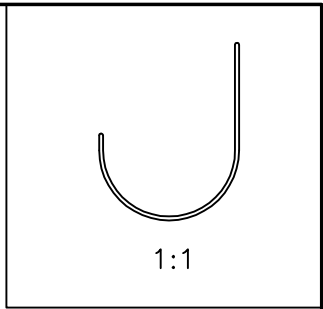

1. GENERAL WALL THICKNESS :- 0.52 mm.
2. NO. OF PIECES IN 100 kgs :- 435 (AVERAGE)

JINDAL ALUMINIUM LTD. BANGALORE-560073		NAME	DATE
		DRAWN	R.D.Sharma 09-02-98
1. ALL DIMENSIONS ARE IN mm. 2. ROUND OFF ALL SHARP CORNERS WITH 0.4 mm. 3. TOLERANCES WILL BE AS PER IS: 3965-1981 ,UNLESS OTHERWISE SPECIFIED		CHECKED	
		APPROVED	
		SCALE	2:1
PARTY'S NAME	GENERAL CATEGORY	WEIGHT kg/m	0.063
PARTY'S DRAWING No.	NIL	SECTION No.	23507
ALLOY & TEMPER	HE9 WP	DRAWING No.	23507
LENGTH	3658 mm.		
DESCRIPTION	WATER CHANNEL		