

P-5464

17609

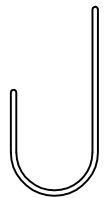

1:1

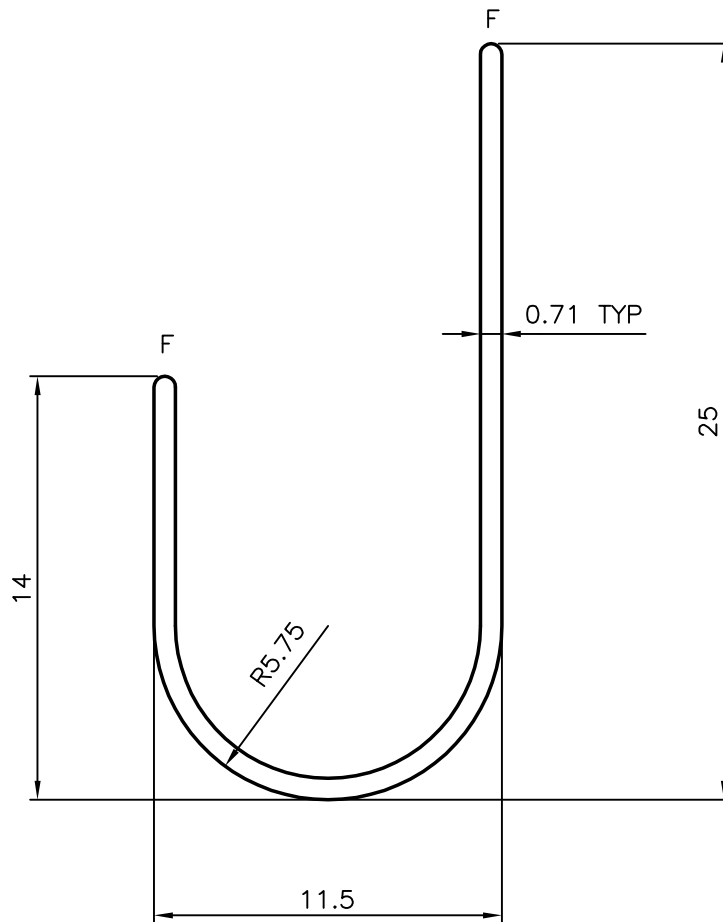

AVERAGE WEIGHT:- 0.310 kg/3658 mm

F = FULL RADIUS (2 PLACES)



SYMBOL OF QUALITY  
AN ISO 9001 COMPANY

**JINDAL ALUMINIUM LTD.**  
BANGALORE-560073 (INDIA)

	NAME	DATE
DRAWN	MALINGAPPA	27-04-2005
CHECKED		
APPROVED		
SCALE		4:1
AREA mm <sup>2</sup>		31.451
PERIMETER mm.		89.708
WEIGHT kg/m		0.085
DRAWING No.		SECTION No.
P-5464		-
23508		23508

1. ALL DIMENSIONS ARE IN mm.
2. ROUND OFF ALL SHARP CORNERS WITH 0.40 mm.
3. TOLERANCES WILL BE AS PER IS:3965-1981 UNLESS OTHERWISE SPECIFIED

PARTY'S NAME	GENERAL CATEGORY, KOLKATA MARKET
PARTY'S DRAWING No.	AS PER SAMPLE/WEIGHT
ALLOY & TEMPER	HE9 WP
DESCRIPTION	WATER CHANNEL