

5419

23556

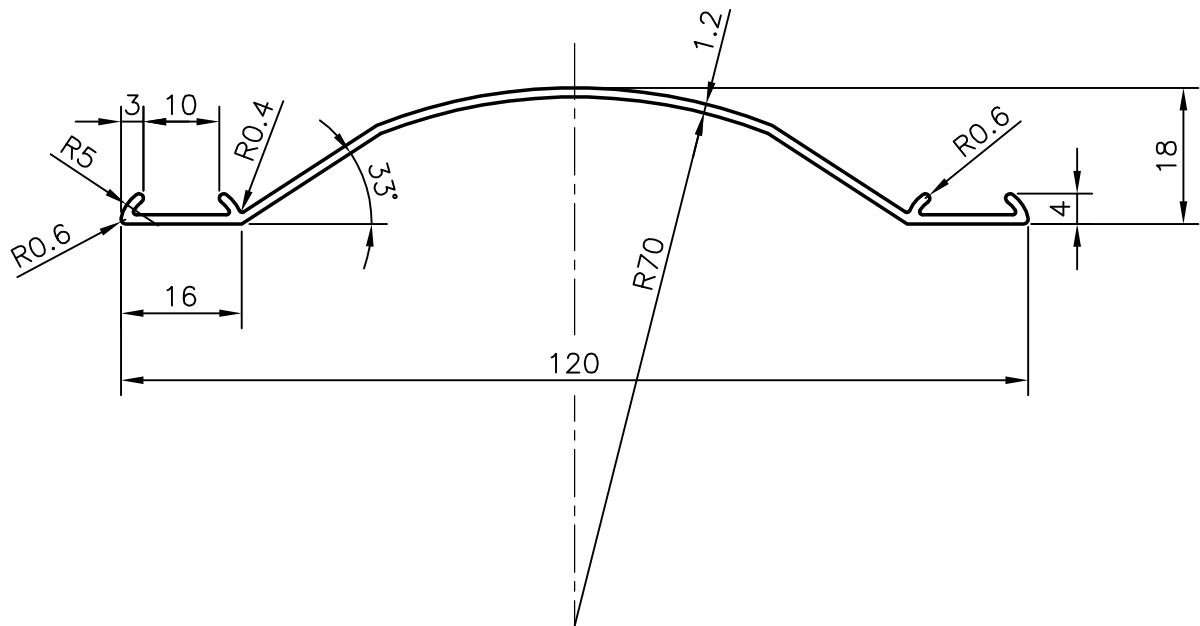

GENERAL WALL THICKNESS:- 1.2 mm.

JINDAL ALUMINIUM LTD.

BANGALORE-560073

NAME

DATE

DRAWN

RAGHAVENDRA

05-12-01

CHECKED

APPROVED

1. ALL DIMENSIONS ARE IN mm.

2. ROUND OFF ALL SHARP CORNERS WITH 0.4 mm.

3. TOLERANCES WILL BE AS PER IS: 3965-1981 ,UNLESS OTHERWISE SPECIFIED

PARTY'S NAME

-

SCALE

1:1

PARTY'S DRAWING No.

-

WEIGHT kg/m

0.486

ALLOY & TEMPER

HE9 WP

SECTION No.

23556

LENGTH

-

DRAWING No.

DESCRIPTION

BEADING

23556