

5453

23580

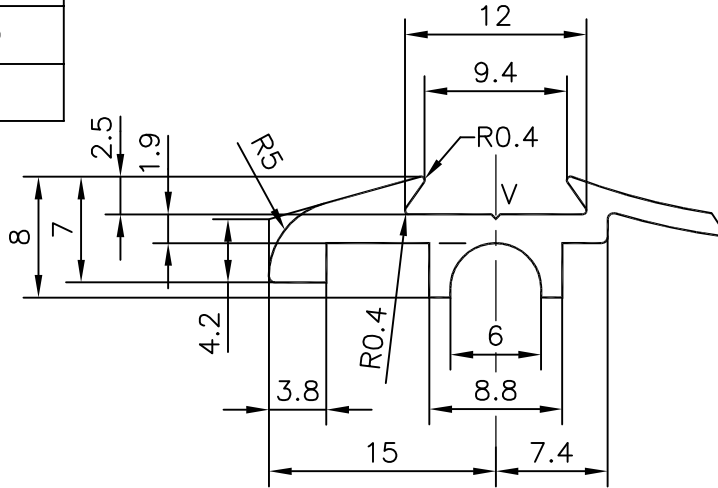

DETAIL AT "A"

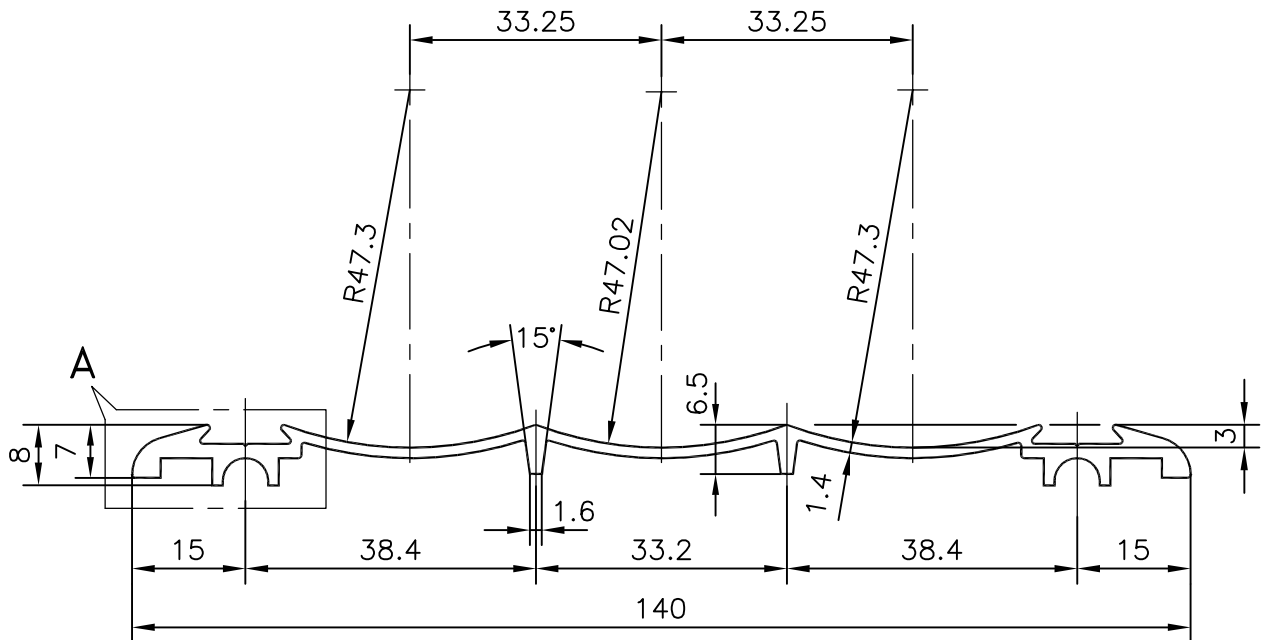

1. V = 0.3x90° V GROOVE(2)

JINDAL ALUMINIUM LTD.**BANGALORE-560073**

NAME

DATE

DRAWN

R.D.Sharma

3-11-95

CHECKED

APPROVED

1. ALL DIMENSIONS ARE IN mm.

2. ROUND OFF ALL SHARP CORNERS WITH 0.4 mm.

3. TOLERANCES WILL BE AS PER IS: 3965-1981 ,UNLESS OTHERWISE SPECIFIED

PARTY'S NAME

A.ABDUL RAHIM OOSMAN & CO.,MAURITIUS

SCALE

1:1 & 2:1

PARTY'S DRAWING No.

AS PER SAMPLE

WEIGHT kg/m

0.845

ALLOY & TEMPER

HE9 WP (6063 T6)

SECTION No.

23580

LENGTH

5500 mm.

DRAWING No.

DESCRIPTION

DECORATIVE BEADING

23580