

5617

23760

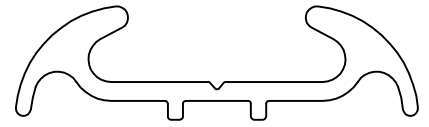

1:1

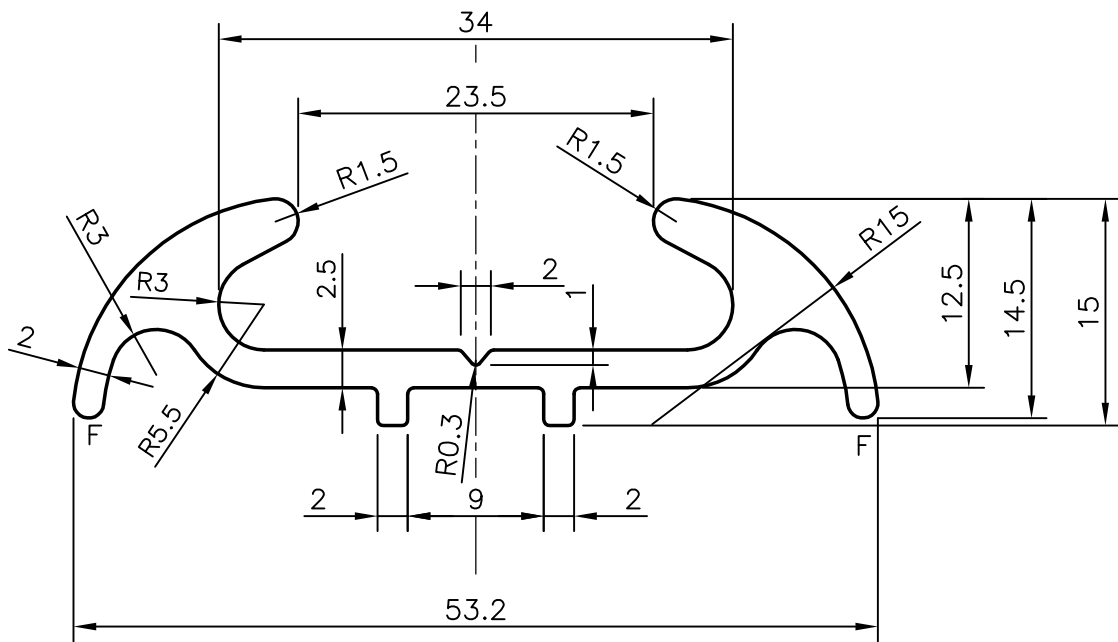

F = FULL RADIUS ( 2 PLACES)



SYMBOL OF QUALITY  
AN ISO 9001 COMPANY

**JINDAL ALUMINIUM LTD.**  
BANGALORE-560073 (INDIA)

	NAME	DATE
DRAWN	J.P.KAUSHIK	12-05-2010
CHECKED		
APPROVED	S.S.GARG	12-05-2010
SCALE		2:1
AREA mm <sup>2</sup>		248.762
PERIMETER mm.		173.446
WEIGHT kg/m		0.672

1. ALL DIMENSIONS ARE IN mm.
2. ROUND OFF ALL SHARP CORNERS WITH 0.40 mm.
3. TOLERANCES WILL BE AS PER IS:3965-1981 UNLESS OTHERWISE SPECIFIED

PARTY'S NAME	-	DRAWING No.	5617	SECTION No.	5617
PARTY'S DRAWING No.	-	23760	23760		
ALLOY & TEMPER	HE9 WP				
DESCRIPTION	SHOW BEADING SECTION				