

5662

23793

-

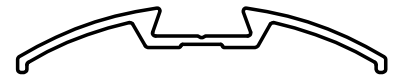

SCALE 1:1

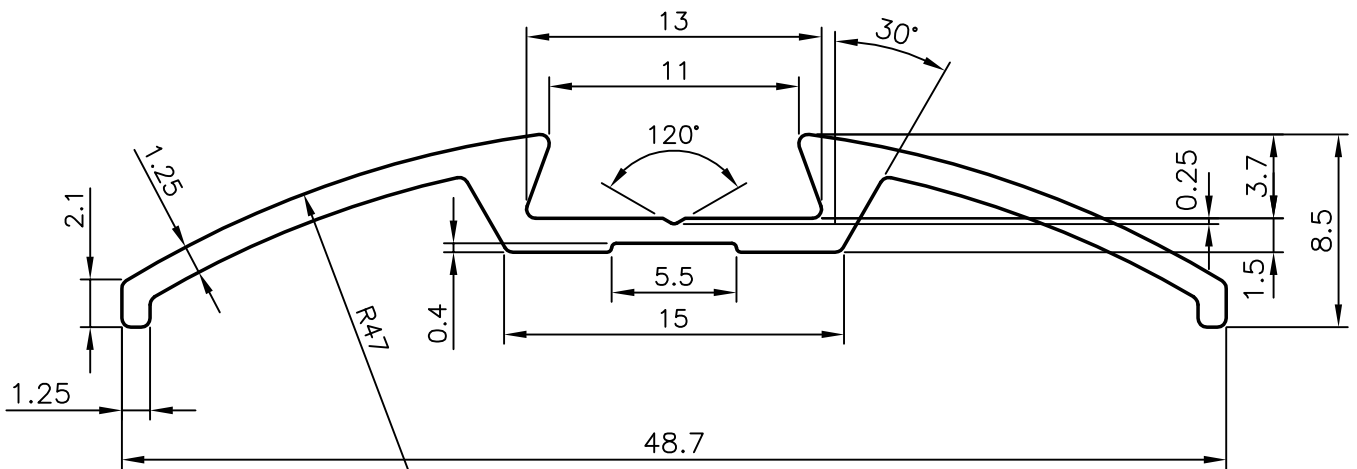

REQD WEIGHT OF 12 LONG PIECE:-0.850 kgs



SYMBOL OF QUALITY  
AN ISO 9001 COMPANY

**JINDAL ALUMINIUM LTD.**  
BANGALORE-560073 (INDIA)

	NAME	DATE
DRAWN	PRASANNA.H.	25-12-2006
CHECKED		
APPROVED		

1. ALL DIMENSIONS ARE IN mm.
2. ROUND OFF ALL SHARP CORNERS WITH 0.40 mm.
3. TOLERANCES WILL BE AS PER IS:3965-1981 UNLESS OTHERWISE SPECIFIED

SCALE	3:1
AREA mm <sup>2</sup>	84.239
PERIMETER mm.	120.861
WEIGHT kg/m	0.232

PARTY'S NAME	-	DRAWING No.	5662	SECTION No.	5662
PARTY'S DRAWING No.	-	23793	23793		
ALLOY & TEMPER	HE9 WP	-	-		
DESCRIPTION	CHABI GOLA (DELUXE)				